



EXACT

Radiant convectors



About the Company

The ISAN trademark represents a traditional Czech manufacturer of heating units with a history that goes back more than 60 years. ISAN Radiátory s.r.o. has been involved in the development and manufacture of convectors for over 20 years. First-rate technological procedures and the progressive thinking of our designers and developers invariably guarantee that ISAN products continue to achieve high-level technical and aesthetic parameters, which have allowed them to become the products of choice among both domestic and foreign customers. We export 90% of our production primarily into EU countries.

Our primary objective is customer satisfaction. Product processing consistent with ecological best practice and utmost consideration for the environment goes without saying.

The manufacture conforms to ISO 9001:2016. Moreover, all heating units comply with certification requirements applicable to current statutory regulations of individual countries in order to conform to the most stringent standards. The certification process for the Czech Republic was completed at the Testing Institute for Mechanical Engineering in Brno, notified body ES1015.

The complete ISAN portfolio consists of a wide range of radiant convectors and lamella-fitted radiators ISAN EXACT, convectors with a lamella heat exchanger ISAN ECOLITE, convectors ISAN TERMO, column radiators ISAN ATOL, ribbed-tube radiators ISAN SPIRAL, glass radiators ISAN JOY and, last but not least, bathroom radiators ISAN MELODY.

ISAN Radiátory s.r.o. specialises in the manufacture of custom-made radiators according to customer requirements and specifications.

Warmth that will adapt ...

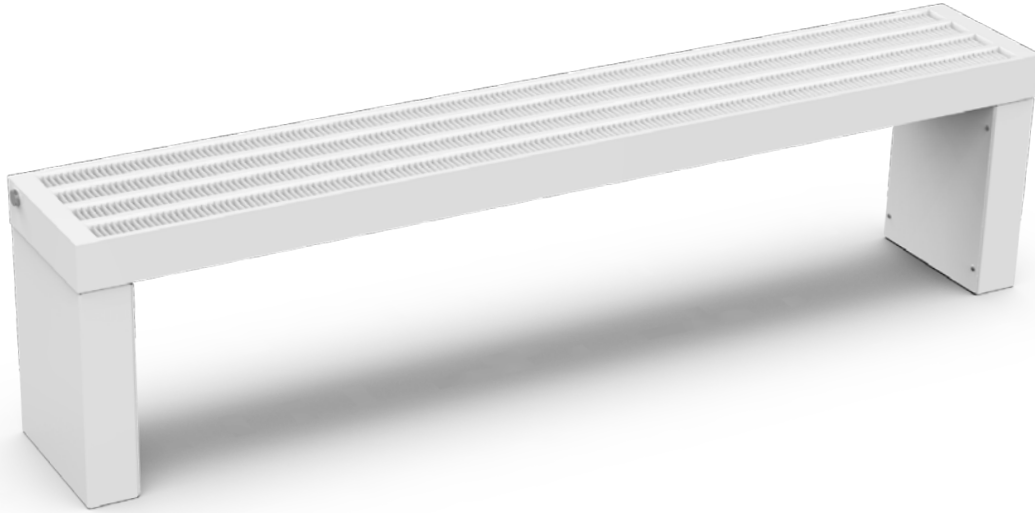

Contents

About the Company	2	Convector Parameters	25
Exact Basic Information	4	Heating medium volume	
Radiant convectors	6	Weight specifications	
K21 / K22 / K22W		Convector Design Options	26
K32 / K33 / K33W		Atypical lengths, Angled radiant convector	
K43 / K44 / K44W		Curve, Facade radiant convector	
K54 / K55 / K55W		Suspended convectors	
Heating output of convectors	10	Convectors with a wooden top	
$\Delta T=60$ K		Convectors for sanitary environments	
$\Delta T=50$ K		Top grille, Alternative fixing methods	
$\Delta T=40$ K		Complementary Products	30
$\Delta T=30$ K		Horizontal radiators with heat transfer fins	
Floor stands and wall brackets	14	Horizontal radiators without fins	
Floor stands		Vertical radiators without fins	
Wall brackets		Exact Convector Technical Drawings	34
Accessories	19	Colour Reference Chart	40
Heating System Connection	20	Coding	41
Type of connections			
Thermostatic Packs	22		

Basic Information

Application

Radiant convectors are a popular alternative to heating modern interiors. They can be installed in front of large glass walls or windows with low window sills, in the interior open space, as well as on the wall. The units feature a significant convection heating component (heated air flow), while providing a pleasant radiant heat. The broad selection ranges from small, refined models to high-performance, robust heating units. Installations in front of windows require models fitted with a thermal shield (models marked W) to prevent heat from escaping outside.

Lamella-fitted radiators are exclusive wall-mounted units, introducing an aesthetic element to the interior. The smooth front panel with fine lines gives this radiator, made of sturdy steel profiles, the impression of a subdued force. Radiant heaters are ideal for those looking for a solid steel structure, efficient appearance and good heat output. Radiators with additional radiant surfaces and fins on the inside are designed for high performance, often installed in older buildings.

- modern households, luxury interiors
- historic buildings, residences
- corridors, commercial premises

Models without the inner fins and the top grille should be placed in areas with stricter hygiene requirements (clean/sterile environments). All nooks and crannies can be easily wiped clean with a cloth and liquid detergent.

- hospitals
- medical facilities
- waiting rooms

Operation

The heat output of convectors with natural convection is controlled by a thermostatic head mounted on the unit's thermostatic valve. It responds to ambient temperature fluctuations and smoothly controls the flow of the heating fluid through the convector.

Convectors and lamellar radiators are designed for use within heating systems in both individual houses and buildings with multiple units that rely solely on heating (treated) water supplied via forced circulation.

Heat output

The heat output was determined in accordance with EN442. Variables with an adverse effect on the heat output include installation of heating units on other than perimeter walls, failure to maintain the required radiator-to-wall clearance or the use of various covers or window sills. The top grille reduces the heat output by approximately 5%.

Position and function

Convector heaters are normally positioned in front of windows to ensure optimum air circulation in front of the glass surface. Ideally, it is best if the unit occupies as much of the width of the window as practically possible. In addition, the height of each unit should be sized with regard to the character of the room as well as the height of the window sill. Wall-mounted models can be anchored under the window sill or to one of the inner walls.

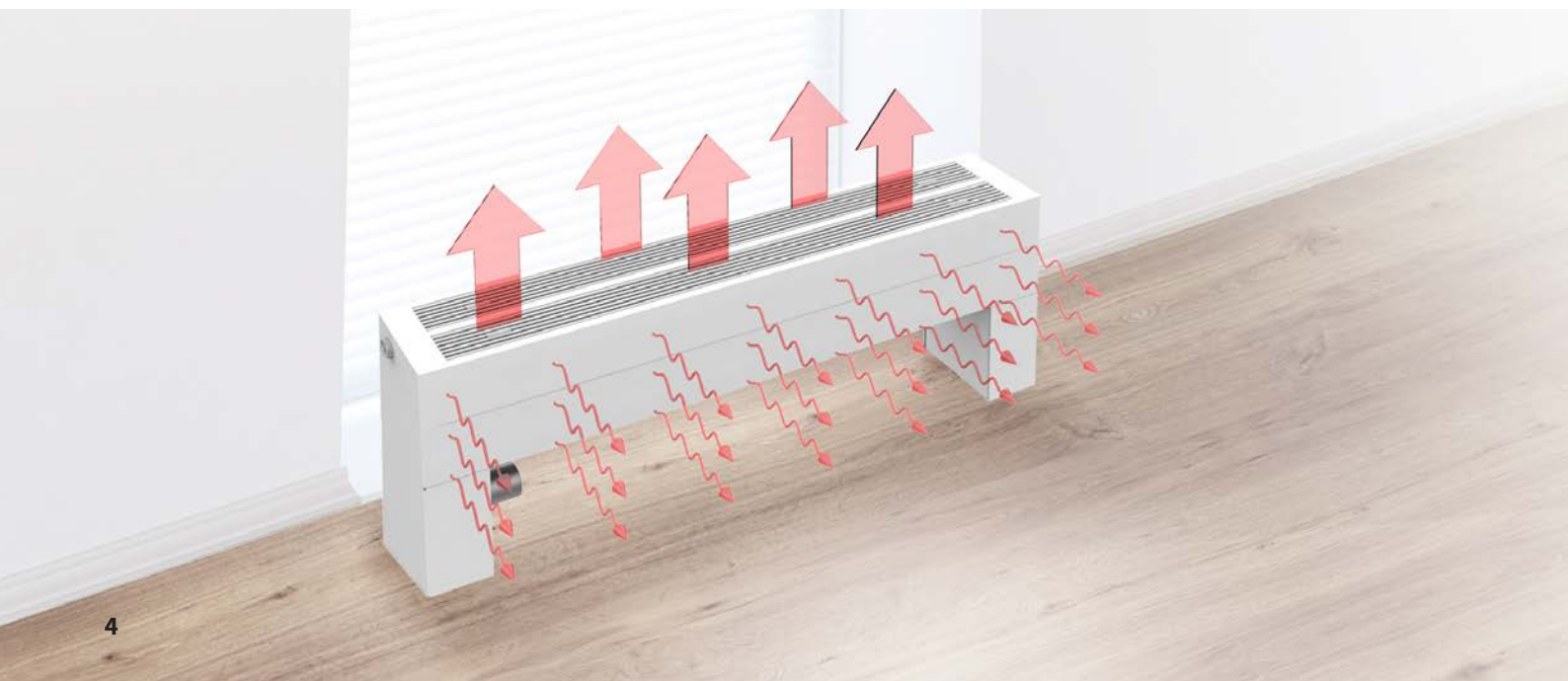
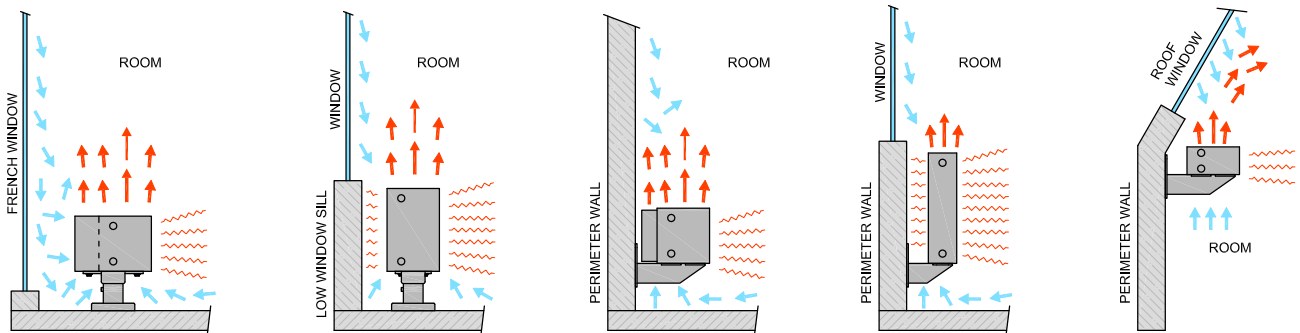

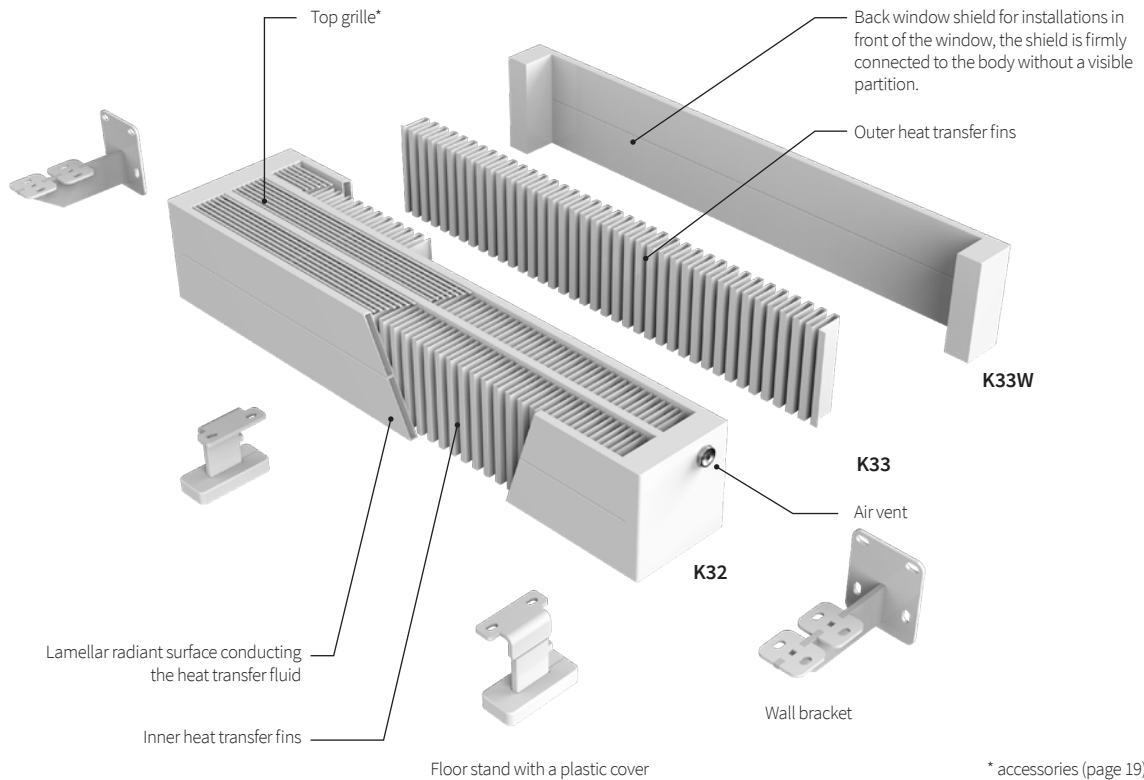

Design

The EXACT units are characterized by their robust design with a sturdy welded frame. The base structure is made up of 70x11mm rectangular profiles (making it possible to increase the size in 70mm increments) joined to form a single piece. Fins inserted between the lamellar panels provide an additional convection surface, effectively boosting the heat output. The robust design essentially increases the weight of the unit, often exceeding 100 kg, which should be taken into account when planning the installation, i.e. choosing a stable substrate with sufficient load-bearing capacity. The convectors are available in a 6 bar design (10 bar versions available to order) and lamellar radiators in 5 bar versions (10 bar to order).

Identification system

K32	3 radiant surfaces, 2 finned surfaces
K33	3 radiant surfaces, 3 finned surfaces
K33W	3 radiant surfaces, 3 finned surfaces, window shield

Surface finish

The surface finish is applied in a manner that is considerate to the environment, provides a long-term corrosion and mechanical resistance and conforms to sanitary standards. We use epoxy polyester powder coating for the finish. Snow white RAL 9016 is the basic colour. For additional colours see the ISAN Colour Reference Chart, subject to a surcharge based on the colour type. The EXACT radiators are not available in chrome and stainless steel versions.

Atypical design and connection

The Exact heating units are highly flexible in terms of their design and connection options.

Design

- the units can be ordered in 1cm length increments within the length limits of each convector
- atypical height variations available in 70mm increments
- curved and angled convector radiators
- radiators and convectors without grilles and fins – sanitary design
- convectors with a wooden top
- atypical floor stands and wall brackets
- church bench design
- facade heating
- raised floor stands

Alternative connection options

- G3/4" heating fluid connection threads
- 50mm lower connection without a valve insert
- one-sided in-line connection
- single-inlet versions

K21 / K22 / K22W

Narrow convectors can both warm up and provide radiant heat to a space. The 70 mm high units can be used as part of façade heating systems or built into church pews. Higher models achieve an optimal radiation-convection ratio, while ensuring an adequate heat output. The units are inconspicuous, aesthetic and efficient. They are a good fit for bedrooms, offices, hallways as well as warehouses, which makes them very versatile in their application.

Basic data

Length L	400–6 000 mm
Height H	70, 140, 210, 280 mm
Connection	4× G1/2"

Operating conditions

Max. operating excess pressure	0,6 MPa (1,0 MPa)
Max. operating temperature	110 °C
Heating system	two-pipe with forced circulation
Ambient temperature	+2 to 45 °C
Relative humidity	20–70 %

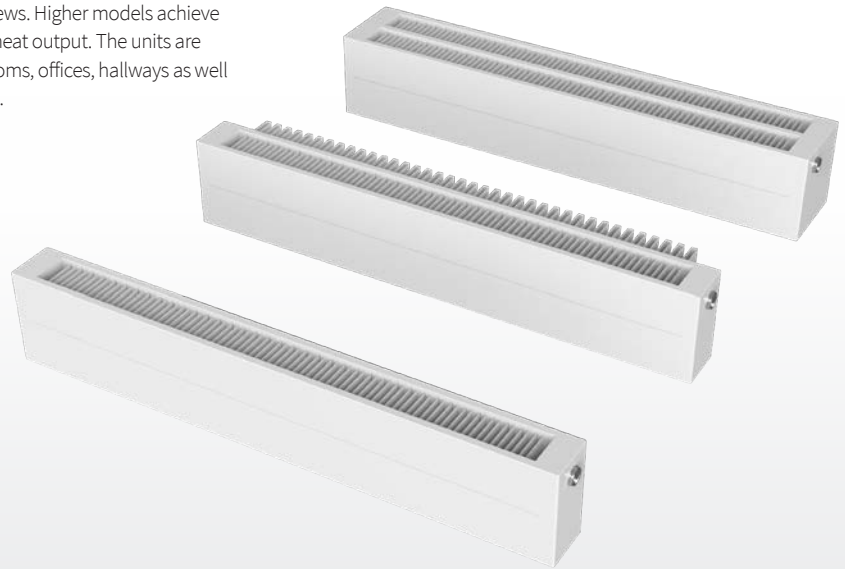

Convector dimensions and options

Convector width W [mm]



K21 2 radiant surfaces 1 finned surface	K22 2 radiant surfaces 2 finned surfaces	K22W 2 radiant surfaces 2 finned surfaces window shield W
--	---	---

Convector height H [mm]

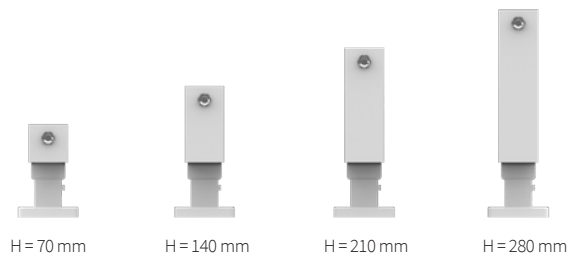

Heating outputs W/m at ΔT50 (ΔT30)

Model	K21	K22, K22W
H = 70 mm	336 W (173 W)	435 W (223 W)
H = 140 mm	524 W (270 W)	693 W (357 W)
H = 210 mm	683 W (352 W)	900 W (465 W)
H = 280 mm	826 W (425 W)	1 077 W (558 W)

Installation

Floor installation



Wall installation



Coding

K22-	0140	2600	VR	F2	D	01	N
Model	Height H [mm]	Length L [mm]	Connection type	Mounting	Grille	Colour	Atypical
K21-	0070	0400 (in step 100)	AB, CD side	F2 floor Subtle	– no grille (standard)	As per RAL colour chart	– standard design
K22-	0140	0500	AD, CB diagonal	F6 floor Tall	L linear	Structured colours	N atypical design
K22W	0210	...	EF, FE bottom	S1 floor Block	D rectangle	Metallic colours	X design 1 MPa (10 bar)
	0280	2000	SM, MS middle	W2 wall Subtle	V round holes	see colour reference chart p. 40	T design 1 MPa (10 bar) and atypical design
		2200 (in step 200)	VL, VR with valve	R1 floor (VDI6036, class 3)			
		2400	SR, ML middle with valve	R2			
	For additional types see p. 20	R3			
	6000	6000					

K32 / K33 / K33W

The most popular convectors, compact adequate dimensions with a sufficient heat output for most applications ranging from apartments, offices and commercial premises to waiting rooms, hallways and warehouses. The convectors are available in a wide range of connection options. Models fitted with a choice of wooden tops remain an exceedingly popular alternative.

Basic data

Length L	400–6 000 mm
Height H	70, 140, 210, 280 mm
Connection	4× G1/2"

Operating conditions

Max. operating excess pressure	0,6 MPa (1,0 MPa)
Max. operating temperature	110 °C
Heating system	two-pipe with forced circulation
Ambient temperature	+2 to 45 °C
Relative humidity	20–70 %

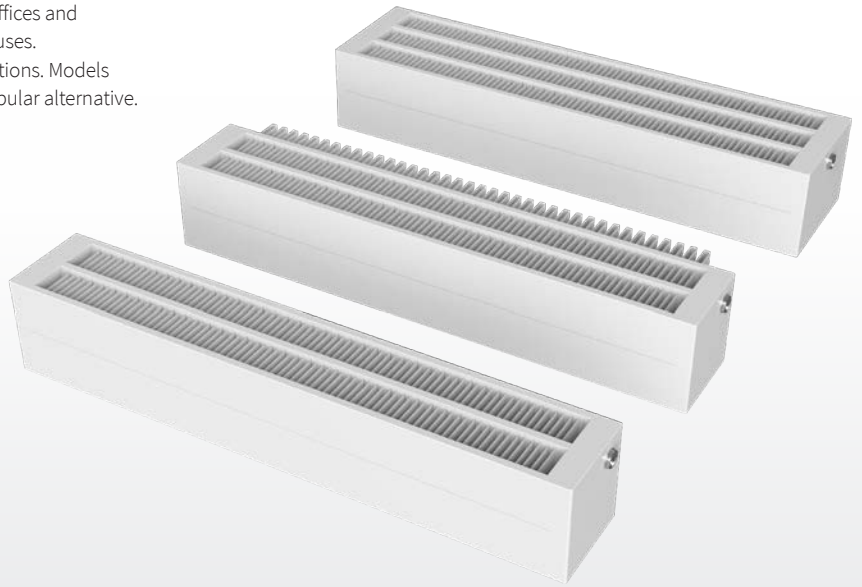

Convector dimensions and options

Convector width W [mm]

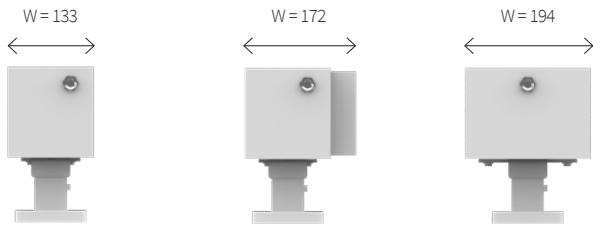

K32 3 radiant surfaces 2 finned surfaces	K33 3 radiant surfaces 3 finned surfaces	K33W 3 radiant surfaces 3 finned surfaces window shield W
---	---	---

Convector height H [mm]

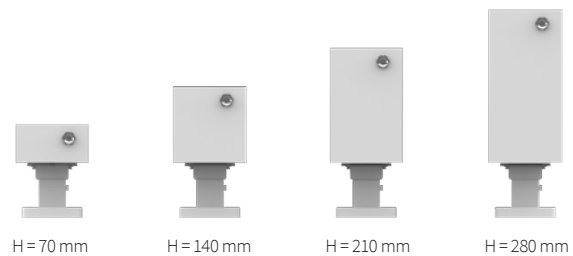

Heating outputs W/m at ΔT50 (ΔT30)

Model	K32	K33, K33W
H = 70 mm	578 W (298 W)	666 W (342 W)
H = 140 mm	903 W (466 W)	1 060 W (546 W)
H = 210 mm	1 176 W (606 W)	1 378 W (712 W)
H = 280 mm	1 422 W (732 W)	1 648 W (854 W)

Installation

Floor installation



Wall installation



Coding

K22-	0140	2600	VR	F2	D	01	N
Model	Height H [mm]	Length L [mm]	Connection type	Mounting	Grille	Colour	Atypical
K32-	0070	0400 (in step 100)	AB, CD side	F2 floor Subtle	– no grille (standard)	As per RAL colour chart	– standard design
K32-	0140	0500	AD, CB diagonal	F6 floor Tall	L linear	Structured colours	N atypical design
K32W	0210	...	EF, FE bottom	S1 floor Block	D rectangle	Metallic colours	X design 1 MPa (10 bar)
	0280	2000	SM, MS middle	W2 wall Subtle	V round holes	see colour reference chart p. 40	T design 1 MPa (10 bar) and atypical design
		2200 (in step 200)	VL, VR with valve	R1 floor			
		2400	SR, ML middle with valve	R2 (VDI6036, class 3)			
	For additional types see p. 20	R3			
	6000	6000					

connection options → 20

connection fittings → 22

accessories → 19

technical drawings → 33

K43 / K44 / K44W

Not all interiors lend themselves to conventional high radiators. High-performance units with 4 radiant surfaces make it possible to meet higher heat requirements, especially in systems with lower heating medium temperatures. The radiant component is substantially complemented by convection heat.

Basic data

Length L	400–6 000 mm
Height H	70, 140, 210, 280 mm
Connection	4× G1/2"

Operating conditions

Max. operating excess pressure	0,6 MPa (1,0 MPa)
Max. operating temperature	110 °C
Heating system	two-pipe with forced circulation
Ambient temperature	+2 to 45 °C
Relative humidity	20–70 %

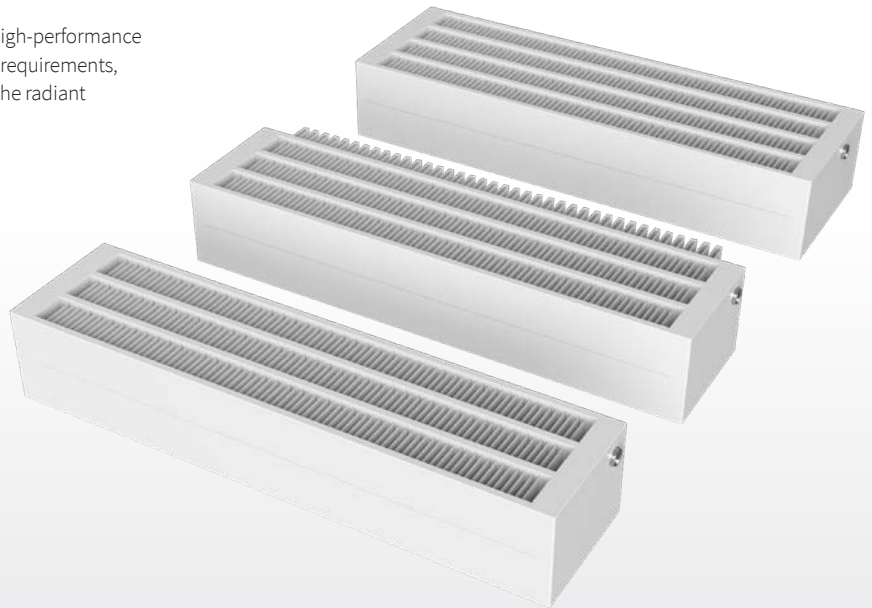

Convactor dimensions and options

Convactor width W [mm]

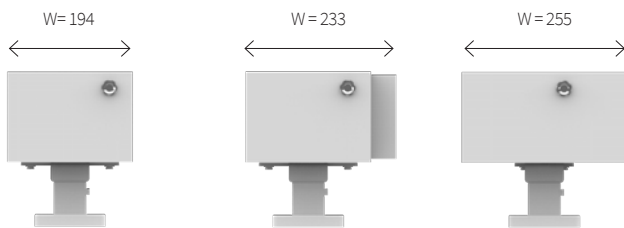

K43	K44	K44W
4 radiant surfaces 3 finned surfaces	4 radiant surfaces 4 finned surfaces	4 radiant surfaces 4 finned surfaces window shield W

Convactor height H [mm]

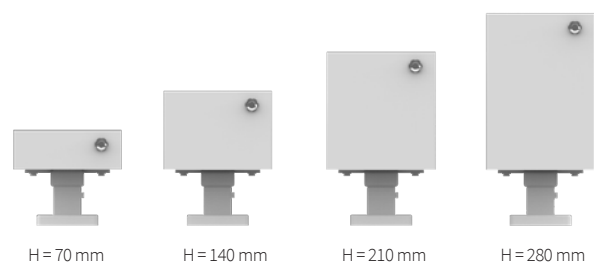

Heating outputs W/m at ΔT50 (ΔT30)

Model	K43	K44, K44W
H = 70 mm	809 W (418 W)	891 W (457 W)
H = 140 mm	1 263 W (651 W)	1 417 W (730 W)
H = 210 mm	1 645 W (847 W)	1 841 W (951 W)
H = 280 mm	1 990 W (1 024 W)	2 202 W (1 141 W)

Installation

Floor installation



Wall installation

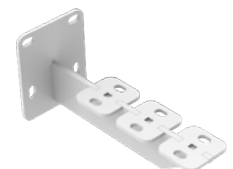

Coding

K22-	0140	2600	VR	F2	D	01	N
Model	Height H [mm]	Length L [mm]	Connection type	Mounting	Grille	Colour	Atypical
K43-	0070	0400 (in step 100)	AB, CD side	F2 floor Subtle	– no grille (standard)	As per RAL colour chart	– standard design
K44-	0140	0500	AD, CB diagonal	F6 floor Tall	L linear	Structured colours	N atypical design
K44W	0210	...	EF, FE bottom	S1 floor Block	D rectangle	Metallic colours	X design 1 MPa (10 bar)
	0280	2000	SM, MS middle	W2 wall Subtle	V round holes	see colour reference chart p. 40	T design 1 MPa (10 bar) and atypical design
		2200 (in step 200)	VL, VR with valve	R1 floor			
		2400	SR, ML middle with valve	R2 (VDI6036, class 3)			
		...	For additional types see p. 20	R3			
		6000					

connection options → 20

connection fittings → 22

accessories → 19

technical drawings → 33

K54 / K55 / K55W

Open-plan and high-ceiling spaces in particular require powerful units to provide adequate heating. Common in historic buildings where high heat loss is a concern. Some models can be integrated into a shaft or used as an artistic, massive monolith. Higher radiant and convection heat output but also greater weight, which should be compensated for by appropriate anchoring.

Basic data

Length L	400–6 000 mm
Height H	70, 140, 210, 280 mm
Connection	4× G1/2"

Operating conditions

Max. operating excess pressure	0,6 MPa (1,0 MPa)
Max. operating temperature	110 °C
Heating system	two-pipe with forced circulation
Ambient temperature	+2 to 45 °C
Relative humidity	20–70 %

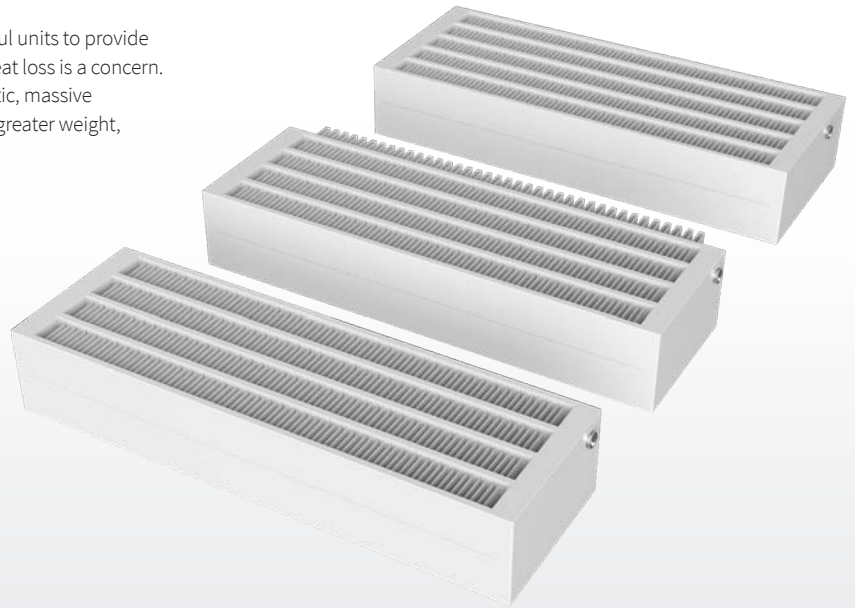

Convector dimensions and options

Convector width W [mm]

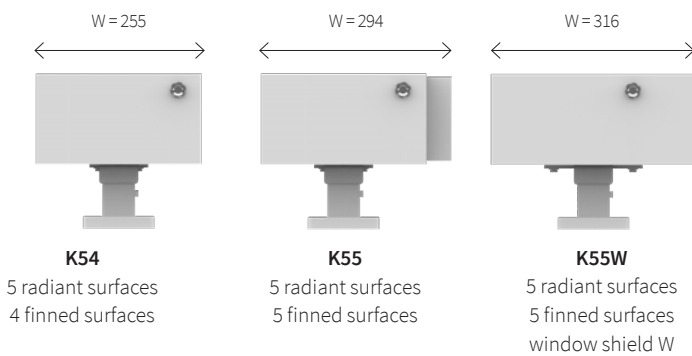

Convector height H [mm]

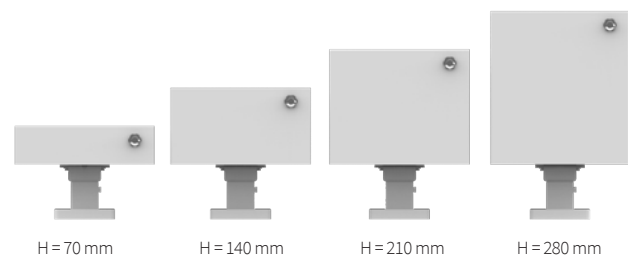

Heating outputs W/m at ΔT50 (ΔT30)

Model	K54	K55, K55W
H = 70 mm	1 028 W (531 W)	1 100 W (570 W)
H = 140 mm	1 606 W (828 W)	1 766 W (909 W)
H = 210 mm	2 092 W (1 078 W)	2 295 W (1 185 W)
H = 280 mm	2 530 W (1 302 W)	2 745 W (1 422 W)

Installation

Floor installation



Wall installation

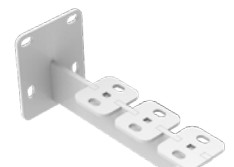

Coding

K22-	0140	2600	VR	F2	D	01	N
Model	Height H [mm]	Length L [mm]	Connection type	Mounting	Grille	Colour	Atypical
K54-	0070	0400 (in step 100)	AB, CD side	F2 floor Subtle	– no grille	As per RAL colour chart	– standard design
K55-	0140	0500	AD, CB diagonal	F6 floor Tall	(standard)	Structured colours	N atypical design
K55W	0210	...	EF, FE bottom	S1 floor Block	L linear	Metallic colours	X design 1 MPa (10 bar)
	0280	2000	SM, MS middle	W2 wall Subtle	D rectangle	see colour reference chart p. 40	T design 1 MPa (10 bar) and atypical design
		2200 (in step 200)	VL, VR with valve	R1 floor	V round holes		
		2400	SR, ML middle with valve	R2 (VDI6036, class 3)			
		6000	For additional types see p. 20	R3			

Heating output of convectors $\Delta T=60\text{ K}$

90 / 70 / 20 °C, ($\Delta T=60\text{K}$) 400–2 400 mm

Height [mm]	Model	n [-]	Length [mm]																		
			400	500	600	700	800	900	1 000	1 100	1 200	1 300	1 400	1 500	1 600	1 700	1 800	1 900	2 000	2 200	2 400
70 mm	K21	1,294	170	213	255	298	340	383	425	468	510	553	596	638	681	723	766	808	851	936	1 021
	K22, K22W	1,305	221	276	331	386	441	497	552	607	662	717	773	828	883	938	993	1 049	1 104	1 214	1 324
	K32	1,294	293	366	439	512	585	659	732	805	878	951	1 025	1 098	1 171	1 244	1 317	1 390	1 464	1 610	1 756
	K33, K33W	1,305	338	422	507	591	676	760	845	929	1 014	1 098	1 183	1 267	1 352	1 436	1 521	1 605	1 690	1 859	2 028
	K43	1,294	410	512	615	717	819	922	1 024	1 127	1 229	1 332	1 434	1 536	1 639	1 741	1 844	1 946	2 049	2 253	2 458
	K44, K44W	1,305	452	565	678	791	904	1 017	1 130	1 243	1 356	1 469	1 582	1 696	1 809	1 922	2 035	2 148	2 261	2 487	2 713
	K54	1,294	521	651	781	911	1 041	1 171	1 302	1 432	1 562	1 692	1 822	1 952	2 082	2 213	2 343	2 473	2 603	2 863	3 124
K55, K55W	1,305	558	698	837	977	1 116	1 256	1 395	1 535	1 675	1 814	1 954	2 093	2 233	2 372	2 512	2 651	2 791	3 070	3 349	
140 mm	K21	1,296	265	332	398	465	531	597	664	730	796	863	929	996	1 062	1 128	1 195	1 261	1 327	1 460	1 593
	K22, K22W	1,299	351	439	527	615	703	790	878	966	1 054	1 142	1 229	1 317	1 405	1 493	1 581	1 669	1 756	1 932	2 108
	K32	1,296	457	572	686	801	915	1 029	1 144	1 258	1 372	1 487	1 601	1 716	1 830	1 944	2 059	2 173	2 287	2 516	2 745
	K33, K33W	1,299	537	672	806	940	1 075	1 209	1 343	1 478	1 612	1 746	1 881	2 015	2 149	2 284	2 418	2 552	2 687	2 955	3 224
	K43	1,296	640	800	960	1 120	1 280	1 440	1 600	1 760	1 920	2 080	2 239	2 399	2 559	2 719	2 879	3 039	3 199	3 519	3 839
	K44, K44W	1,299	718	898	1 077	1 257	1 437	1 616	1 796	1 975	2 155	2 334	2 514	2 694	2 873	3 053	3 232	3 412	3 591	3 950	4 310
	K54	1,296	814	1 017	1 220	1 424	1 627	1 831	2 034	2 237	2 441	2 644	2 848	3 051	3 255	3 458	3 661	3 865	4 068	4 475	4 882
K55, K55W	1,299	895	1 119	1 343	1 567	1 790	2 014	2 238	2 462	2 686	2 909	3 133	3 357	3 581	3 804	4 028	4 252	4 476	4 923	5 371	
210 mm	K21	1,299	346	433	519	606	692	779	866	952	1 039	1 125	1 212	1 298	1 385	1 471	1 558	1 644	1 731	1 904	2 077
	K22, K22W	1,293	456	570	684	797	911	1 025	1 139	1 253	1 367	1 481	1 595	1 709	1 823	1 937	2 051	2 165	2 279	2 506	2 734
	K32	1,299	596	745	894	1 043	1 192	1 341	1 490	1 639	1 788	1 937	2 086	2 235	2 384	2 533	2 682	2 832	2 981	3 279	3 577
	K33, K33W	1,293	698	872	1 047	1 221	1 395	1 570	1 744	1 919	2 093	2 268	2 442	2 617	2 791	2 965	3 140	3 314	3 489	3 838	4 186
	K43	1,299	834	1 042	1 251	1 459	1 668	1 876	2 085	2 293	2 502	2 710	2 918	3 127	3 335	3 544	3 752	3 961	4 169	4 586	5 003
	K44, K44W	1,293	932	1 165	1 398	1 631	1 864	2 097	2 330	2 563	2 797	3 030	3 263	3 496	3 729	3 962	4 195	4 428	4 661	5 127	5 593
	K54	1,299	1 060	1 326	1 591	1 856	2 121	2 386	2 651	2 916	3 181	3 446	3 711	3 977	4 242	4 507	4 772	5 037	5 302	5 832	6 363
K55, K55W	1,293	1 162	1 453	1 743	2 034	2 324	2 615	2 905	3 196	3 486	3 777	4 067	4 358	4 648	4 939	5 229	5 520	5 810	6 391	6 972	
280 mm	K21	1,301	419	524	628	733	838	942	1 047	1 152	1 257	1 361	1 466	1 571	1 675	1 780	1 885	1 990	2 094	2 304	2 513
	K22, K22W	1,287	545	681	817	953	1 089	1 226	1 362	1 498	1 634	1 770	1 907	2 043	2 179	2 315	2 451	2 587	2 724	2 996	3 268
	K32	1,301	721	901	1 080	1 262	1 442	1 622	1 803	1 983	2 163	2 343	2 524	2 704	2 884	3 065	3 245	3 425	3 605	3 966	4 326
	K33, K33W	1,287	834	1 042	1 250	1 459	1 667	1 875	2 084	2 292	2 501	2 709	2 917	3 126	3 334	3 543	3 751	3 959	4 168	4 584	5 001
	K43	1,301	1 009	1 261	1 514	1 766	2 018	2 270	2 523	2 775	3 027	3 280	3 532	3 784	4 036	4 289	4 541	4 793	5 045	5 550	6 055
	K44, K44W	1,287	1 114	1 392	1 671	1 949	2 227	2 506	2 784	3 063	3 341	3 620	3 898	4 177	4 455	4 733	5 012	5 290	5 569	6 126	6 682
	K54	1,301	1 283	1 604	1 924	2 245	2 566	2 887	3 207	3 528	3 849	4 169	4 490	4 811	5 132	5 452	5 773	6 094	6 415	7 056	7 697
K55, K55W	1,287	1 388	1 735	2 083	2 430	2 777	3 124	3 471	3 818	4 165	4 512	4 859	5 206	5 554	5 901	6 248	6 595	6 942	7 636	8 330	

90 / 70 / 20 °C, ($\Delta T=60\text{K}$) 2 600–6 000 mm

Height [mm]	Model	n [-]	Length [mm]																	
			2 600	2 800	3 000	3 200	3 400	3 600	3 800	4 000	4 200	4 400	4 600	4 800	5 000	5 200	5 400	5 600	5 800	6 000
70 mm	K21	1,294	1 106	1 191	1 276	1 361	1 446	1 531	1 617	1 702	1 787	1 872	1 957	2 042	2 127	2 212	2 297	2 382	2 467	2 552
	K22, K22W	1,305	1 435	1 545	1 656	1 766	1 876	1 987	2 097	2 207	2 318	2 428	2 539	2 649	2 759	2 870	2 980	3 090	3 201	3 311
	K32	1,294	1 903	2 049	2 195	2 342	2 488	2 634	2 781	2 927	3 074	3 220	3 366	3 513	3 659	3 805	3 952	4 098	4 244	4 391
	K33, K33W	1,305	2 197	2 366	2 535	2 704	2 873	3 042	3 211	3 380	3 549	3 718	3 887	4 056	4 225	4 393	4 562	4 731	4 900	5 069
	K43	1,294	2 663	2 868	3 073	3 278	3 482	3 687	3 892	4 097	4 302	4 507	4 712	4 916	5 121	5 326	5 531	5 736	5 941	6 146
	K44, K44W	1,305	2 939	3 165	3 391	3 617	3 843	4 069	4 295	4 521	4 747	4 973	5 200	5 426	5 652	5 878	6 104	6 330	6 556	6 782
	K54	1,294	3 384	3 644	3 905	4 165	4 425	4 686	4 946	5 206	5 466	5 727	5 987	6 247	6 508	6 768	7 028	7 289	7 549	7 809
K55, K55W	1,305	3 628	3 907	4 186	4 466	4 745	5 024	5 303	5 582	5 861	6 140	6 419	6 698	6 977	7 257	7 536	7 815	8 094	8 373	
140 mm	K21	1,296	1 726	1 858	1 991	2 124	2 256	2 389	2 522	2 655	2 787	2 920	3 053	3 186	3 318	3 451	3 584	3 717	3 849	3 982
	K22, K22W	1,299	2 283	2 459	2 635	2 810	2 986	3 161	3 337	3 513	3 688	3 864	4 040	4 215	4 391	4 567	4 742	4 918	5 094	5 269
	K32	1,296	2 974	3 202	3 431	3 660	3 889	4 117	4 346	4 575	4 803	5 032	5 261	5 490	5 718	5 947	6 176	6 405	6 633	6 862
	K33, K33W	1,299	3 492	3 761	4 030	4 298	4 567	4 836	5 104	5 373	5 642	5 910	6 179	6 448	6 716	6 985	7 254	7 522	7 791	8 060
	K43	1,296	4 159	4 479	4 799	5 119	5 439	5 759	6 079	6 399	6 718	7 038	7 358	7 678	7 998	8 318	8 638	8 958	9 278	9 598
	K44, K44W	1,299	4 669	5 028	5 387	5 746	6 105	6 464	6 824	7 183	7 542	7 901	8 260	8 619	8 978	9 337	9 697	10 056	10 415	10 774
	K54	1,296	5 289	5 695	6 102	6 509	6 916	7 323	7 729	8 136	8 543	8 950	9 357	9 764	10 170	10 577	10 984	11 391	11 798	12 204
K55, K55W	1,299	5 819	6 266	6 714	7 161	7 609	8 057	8 504	8 952	9 399	9 847	10 294	10 742	11 190	11 637	12 085	12 532	12 980	13 428	
210 mm	K21	1,299	2 250	2 423	2 597	2 770	2 943	3 116	3 289	3 462	3 635	3 808	3 981	4 154	4 328	4 501	4 674	4 847	5 020	5 193
	K22, K22W	1,293	2 962	3 190	3 418	3 646	3 873	4 101	4 329	4 557	4 785	5 013	5 241	5 468	5 696	5 924	6 152	6 380	6 608	6 836
	K32	1,299	3 875	4 173	4 471	4 769	5 067	5 365	5 663	5 961	6 259	6 557	6 855	7 153	7 451	7 749	8 047	8 345	8 644	8 942
	K33, K33W	1,293	4 535	4 884	5 233	5 582	5 931	6 280	6 628	6 977	7 326	7 675	8 024	8 373	8 722	9 071	9 419	9 768	10 117	10 466
	K43	1,299	5 420	5 837	6 254	6 671	7 088	7 505	7 921	8 338	8 755	9 172	9 589	10 006	10 423	10 840	11 257	11 674	12 091	12 508
	K44, K44W	1,293	6 059	6 525	6 991	7 457	7 923	8 390	8 856	9 322	9 788	10 254	10 720	11 186	11 652	12 118	12 584	13 050	13 516	13 983
	K54	1,299	6 893	7 423	7 953	8 483	9 014	9 544	10 074	10 604	11 134	11 665	12 195	12 725	13 255	13 785	14 316	14 846	15 376	15 906
K55, K55W	1,293	7 553	8 134	8 715	9 296	9 877	10 458	11 039	11 620	12 202	12 783	13 364	13 945	14 526	15 107	15 6				

Heating output of convectors $\Delta T=50$ K

75 / 65 / 20 °C, ($\Delta T=50$ K) 400–2 400 mm

Height [mm]	Model	n [-]	Length [mm]																		
			400	500	600	700	800	900	1 000	1 100	1 200	1 300	1 400	1 500	1 600	1 700	1 800	1 900	2 000	2 200	2 400
70 mm	K21	1,294	134	168	202	235	269	302	336	370	403	437	470	504	538	571	605	638	672	739	806
	K22, K22W	1,305	174	218	261	305	348	392	435	479	522	566	609	653	696	740	783	827	870	957	1 044
	K32	1,294	231	289	347	405	462	520	578	636	694	751	809	867	925	983	1 040	1 098	1 156	1 272	1 387
	K33, K33W	1,305	266	333	400	466	533	599	666	733	799	866	932	999	1 066	1 132	1 199	1 265	1 332	1 465	1 598
	K43	1,294	324	405	485	566	647	728	809	890	971	1 052	1 133	1 214	1 294	1 375	1 456	1 537	1 618	1 780	1 942
	K44, K44W	1,305	356	446	535	624	713	802	891	980	1 069	1 158	1 247	1 337	1 426	1 515	1 604	1 693	1 782	1 960	2 138
	K54	1,294	411	514	617	720	822	925	1 028	1 131	1 234	1 336	1 439	1 542	1 645	1 748	1 850	1 953	2 056	2 262	2 467
K55, K55W	1,305	440	550	660	770	880	990	1 100	1 210	1 320	1 430	1 540	1 650	1 760	1 870	1 980	2 090	2 200	2 420	2 640	
140 mm	K21	1,296	210	262	314	367	419	472	524	576	629	681	734	786	838	891	943	996	1 048	1 153	1 258
	K22, K22W	1,299	277	347	416	485	554	624	693	762	832	901	970	1 040	1 109	1 178	1 247	1 317	1 386	1 525	1 663
	K32	1,296	361	452	542	632	722	813	903	993	1 084	1 174	1 264	1 355	1 445	1 535	1 625	1 716	1 806	1 987	2 167
	K33, K33W	1,299	424	530	636	742	848	954	1 060	1 166	1 272	1 378	1 484	1 590	1 696	1 802	1 908	2 014	2 120	2 332	2 544
	K43	1,296	505	632	758	884	1 010	1 137	1 263	1 389	1 516	1 642	1 768	1 895	2 021	2 147	2 273	2 400	2 526	2 779	3 031
	K44, K44W	1,299	567	709	850	992	1 134	1 275	1 417	1 559	1 700	1 842	1 984	2 126	2 267	2 409	2 551	2 692	2 834	3 117	3 401
	K54	1,296	642	803	964	1 124	1 285	1 445	1 606	1 767	1 927	2 088	2 248	2 409	2 570	2 730	2 891	3 051	3 212	3 533	3 854
K55, K55W	1,299	706	883	1 060	1 236	1 413	1 589	1 766	1 943	2 119	2 296	2 472	2 649	2 826	3 002	3 179	3 355	3 532	3 885	4 238	
210 mm	K21	1,299	273	342	410	478	546	615	683	751	820	888	956	1 025	1 093	1 161	1 229	1 298	1 366	1 503	1 639
	K22, K22W	1,293	360	450	540	630	720	810	900	990	1 080	1 170	1 260	1 350	1 440	1 530	1 620	1 710	1 800	1 980	2 160
	K32	1,299	470	588	706	823	941	1 058	1 176	1 294	1 411	1 529	1 646	1 764	1 882	1 999	2 117	2 234	2 352	2 587	2 822
	K33, K33W	1,293	551	689	827	965	1 102	1 240	1 378	1 516	1 654	1 791	1 929	2 067	2 205	2 343	2 480	2 618	2 756	3 032	3 307
	K43	1,299	658	823	987	1 152	1 316	1 481	1 645	1 810	1 974	2 139	2 303	2 468	2 632	2 797	2 961	3 126	3 290	3 619	3 948
	K44, K44W	1,293	736	921	1 105	1 289	1 473	1 657	1 841	2 025	2 209	2 393	2 577	2 762	2 946	3 130	3 314	3 498	3 682	4 050	4 418
	K54	1,299	837	1 046	1 255	1 464	1 674	1 883	2 092	2 301	2 510	2 720	2 929	3 138	3 347	3 556	3 766	3 975	4 184	4 602	5 021
K55, K55W	1,293	918	1 148	1 377	1 607	1 836	2 066	2 295	2 525	2 754	2 984	3 213	3 443	3 672	3 902	4 131	4 361	4 590	5 049	5 508	
280 mm	K21	1,301	330	413	496	578	661	743	826	909	991	1 074	1 156	1 239	1 322	1 404	1 487	1 569	1 652	1 817	1 982
	K22, K22W	1,287	431	539	646	754	862	969	1 077	1 185	1 292	1 400	1 508	1 616	1 723	1 831	1 939	2 046	2 154	2 369	2 585
	K32	1,301	569	711	853	995	1 138	1 280	1 422	1 564	1 706	1 849	1 991	2 133	2 275	2 417	2 560	2 702	2 844	3 128	3 413
	K33, K33W	1,287	659	824	989	1 154	1 318	1 483	1 648	1 813	1 978	2 142	2 307	2 472	2 637	2 802	2 966	3 131	3 296	3 626	3 955
	K43	1,301	796	995	1 194	1 393	1 592	1 791	1 990	2 189	2 388	2 587	2 786	2 985	3 184	3 383	3 582	3 781	3 980	4 378	4 776
	K44, K44W	1,287	881	1 101	1 321	1 541	1 762	1 982	2 202	2 422	2 642	2 863	3 083	3 303	3 523	3 743	3 964	4 184	4 404	4 844	5 285
	K54	1,301	1 012	1 265	1 518	1 771	2 024	2 277	2 530	2 783	3 036	3 289	3 542	3 795	4 048	4 301	4 554	4 807	5 060	5 566	6 072
K55, K55W	1,287	1 098	1 373	1 647	1 922	2 196	2 471	2 745	3 020	3 294	3 569	3 843	4 118	4 392	4 667	4 941	5 216	5 490	6 039	6 588	

75 / 65 / 20 °C, ($\Delta T=50$ K) 2 600–6 000 mm

Height [mm]	Model	n [-]	Length [mm]																	
			2 600	2 800	3 000	3 200	3 400	3 600	3 800	4 000	4 200	4 400	4 600	4 800	5 000	5 200	5 400	5 600	5 800	6 000
70 mm	K21	1,294	874	941	1 008	1 075	1 142	1 210	1 277	1 344	1 411	1 478	1 546	1 613	1 680	1 747	1 814	1 882	1 949	2 016
	K22, K22W	1,305	1 131	1 218	1 305	1 392	1 479	1 566	1 653	1 740	1 827	1 914	2 001	2 088	2 175	2 262	2 349	2 436	2 523	2 610
	K32	1,294	1 503	1 618	1 734	1 850	1 965	2 081	2 196	2 312	2 428	2 543	2 659	2 774	2 890	3 006	3 121	3 237	3 352	3 468
	K33, K33W	1,305	1 732	1 865	1 998	2 131	2 264	2 398	2 531	2 664	2 797	2 930	3 064	3 197	3 330	3 463	3 596	3 730	3 863	3 996
	K43	1,294	2 103	2 265	2 427	2 589	2 751	2 912	3 074	3 236	3 398	3 560	3 721	3 883	4 045	4 207	4 369	4 530	4 692	4 854
	K44, K44W	1,305	2 317	2 495	2 673	2 851	3 029	3 208	3 386	3 564	3 742	3 920	4 099	4 277	4 455	4 633	4 811	4 990	5 168	5 346
	K54	1,294	2 673	2 878	3 084	3 290	3 495	3 701	3 906	4 112	4 318	4 523	4 729	4 934	5 140	5 346	5 551	5 757	5 962	6 168
K55, K55W	1,305	2 860	3 080	3 300	3 520	3 740	3 960	4 180	4 400	4 620	4 840	5 060	5 280	5 500	5 720	5 940	6 160	6 380	6 600	
140 mm	K21	1,296	1 362	1 467	1 572	1 677	1 782	1 886	1 991	2 096	2 201	2 306	2 410	2 515	2 620	2 725	2 830	2 934	3 039	3 144
	K22, K22W	1,299	1 802	1 940	2 079	2 218	2 356	2 495	2 633	2 772	2 911	3 049	3 188	3 326	3 465	3 604	3 742	3 881	4 019	4 158
	K32	1,296	2 348	2 528	2 709	2 890	3 070	3 251	3 431	3 612	3 793	3 973	4 154	4 334	4 515	4 696	4 876	5 057	5 237	5 418
	K33, K33W	1,299	2 756	2 968	3 180	3 392	3 604	3 816	4 028	4 240	4 452	4 664	4 876	5 088	5 300	5 512	5 724	5 936	6 148	6 360
	K43	1,296	3 284	3 536	3 789	4 042	4 294	4 547	4 799	5 052	5 305	5 557	5 810	6 062	6 315	6 568	6 820	7 073	7 325	7 578
	K44, K 44W	1,299	3 684	3 968	4 251	4 534	4 818	5 101	5 385	5 668	5 951	6 235	6 518	6 802	7 085	7 368	7 652	7 935	8 219	8 502
	K54	1,296	4 176	4 497	4 818	5 139	5 460	5 782	6 103	6 424	6 745	7 066	7 388	7 709	8 030	8 351	8 672	8 994	9 315	9 636
K55, K55W	1,299	4 592	4 945	5 298	5 651	6 004	6 358	6 711	7 064	7 417	7 770	8 124	8 477	8 830	9 183	9 536	9 890	10 243	10 596	
210 mm	K21	1,299	1 776	1 912	2 049	2 186	2 322	2 459	2 595	2 732	2 869	3 005	3 142	3 278	3 415	3 552	3 688	3 825	3 961	4 098
	K22, K22W	1,293	2 340	2 520	2 700	2 880	3 060	3 240	3 420	3 600	3 780	3 960	4 140	4 320	4 500	4 680	4 860	5 040	5 220	5 400
	K32	1,299	3 058	3 293	3 528	3 763	3 998	4 234	4 469	4 704	4 939	5 174	5 410	5 645	5 880	6 115	6 350	6 586	6 821	7 056
	K33, K33W	1,293	3 583	3 858	4 134	4 410	4 685	4 961	5 236	5 512	5 788	6 063	6 339	6 614	6 890	7 166	7 441	7 717	7 992	8 268
	K43	1,299	4 277	4 606	4 935	5 264	5 593	5 922	6 251	6 580	6 909	7 238	7 567	7 896	8 225	8 554	8 883	9 212	9 541	9 870
	K44, K44W	1,293	4 787	5 155	5 523	5 891	6 259	6 628	6 996	7 364	7 732	8 100	8 469	8 837	9 205	9 573	9 941	10 310	10 678	11 046
	K54	1,299	5 439	5 858	6 276	6 694	7 113	7 531	7 950	8 368	8 786	9 205	9 623	10 042	10 460	10 878	11 297	11 715	12 134	12 552
K55, K55W	1,293	5 967	6 426	6 885	7 344	7 803	8 262	8 721	9 180	9 639	10 098	10 557	11 016	11 475	11 934	12 393	12 852	13 311	13 770	
280 mm	K21	1,301	2 148	2 313	2 478	2 643	2 808	2 974	3 139	3 304	3 469	3 634	3 800							

Heating output of convectors $\Delta T=40\text{ K}$

65 / 55 / 20 °C, ($\Delta T=40\text{K}$) 400–2 400 mm

Height [mm]	Model	n [-]	Length [mm]																		
			400	500	600	700	800	900	1 000	1 100	1 200	1 300	1 400	1 500	1 600	1 700	1 800	1 900	2 000	2 200	2 400
70 mm	K21	1,294	101	126	151	176	201	227	252	277	302	327	352	378	403	428	453	478	503	554	604
	K22, K22W	1,305	130	163	195	228	260	293	325	358	390	423	455	488	520	553	585	618	650	715	780
	K32	1,294	173	217	260	303	346	390	433	476	520	563	606	650	693	736	779	823	866	953	1 039
	K33, K33W	1,305	199	249	299	348	398	448	498	548	597	647	697	747	796	846	896	946	995	1 095	1 195
	K43	1,294	242	303	364	424	485	545	606	667	727	788	849	909	970	1 030	1 091	1 152	1 212	1 333	1 455
	K44, K44W	1,305	266	333	400	466	533	599	666	732	799	866	932	999	1 065	1 132	1 199	1 265	1 332	1 465	1 598
	K54	1,294	308	385	462	539	616	693	770	847	924	1 001	1 078	1 155	1 232	1 309	1 386	1 463	1 540	1 694	1 848
K55, K55W	1,305	329	411	493	575	658	740	822	904	987	1 069	1 151	1 233	1 315	1 398	1 480	1 562	1 644	1 809	1 973	
140 mm	K21	1,296	157	196	235	275	314	353	392	432	471	510	549	589	628	667	706	746	785	863	942
	K22, K22W	1,299	207	259	311	363	415	467	519	570	622	674	726	778	830	882	934	985	1 037	1 141	1 245
	K32	1,296	270	338	406	473	541	609	676	744	811	879	947	1 014	1 082	1 150	1 217	1 285	1 352	1 488	1 623
	K33, K33 W	1,299	317	397	476	555	635	714	793	873	952	1 031	1 111	1 190	1 269	1 349	1 428	1 507	1 587	1 745	1 904
	K43	1,296	378	473	567	662	757	851	946	1 040	1 135	1 230	1 324	1 419	1 513	1 608	1 702	1 797	1 892	2 081	2 270
	K44, K44W	1,299	424	530	636	742	848	954	1 060	1 166	1 273	1 379	1 485	1 591	1 697	1 803	1 909	2 015	2 121	2 333	2 545
	K54	1,296	481	601	722	842	962	1 082	1 203	1 323	1 443	1 563	1 684	1 804	1 924	2 045	2 165	2 285	2 405	2 646	2 886
K55, K55W	1,299	529	661	793	925	1 057	1 189	1 322	1 454	1 586	1 718	1 850	1 982	2 115	2 247	2 379	2 511	2 643	2 908	3 172	
210 mm	K21	1,299	204	256	307	358	409	460	511	562	613	664	716	767	818	869	920	971	1 022	1 124	1 227
	K22, K22W	1,293	270	337	405	472	540	607	674	742	809	877	944	1 012	1 079	1 147	1 214	1 281	1 349	1 484	1 619
	K32	1,299	352	440	528	616	704	792	880	968	1 056	1 144	1 232	1 320	1 408	1 496	1 584	1 672	1 760	1 936	2 112
	K33, K33W	1,293	413	516	620	723	826	929	1 033	1 136	1 239	1 342	1 446	1 549	1 652	1 755	1 859	1 962	2 065	2 272	2 478
	K43	1,299	492	616	739	862	985	1 108	1 231	1 354	1 477	1 600	1 723	1 847	1 970	2 093	2 216	2 339	2 462	2 708	2 955
	K44, K44W	1,293	552	690	828	966	1 104	1 242	1 380	1 518	1 656	1 793	1 931	2 069	2 207	2 345	2 483	2 621	2 759	3 035	3 311
	K54	1,299	626	783	939	1 096	1 252	1 409	1 566	1 722	1 879	2 035	2 192	2 348	2 505	2 661	2 818	2 975	3 131	3 444	3 757
K55, K55W	1,293	688	860	1 032	1 204	1 376	1 548	1 720	1 892	2 064	2 236	2 408	2 580	2 752	2 924	3 096	3 268	3 440	3 784	4 128	
280 mm	K21	1,301	247	309	371	433	494	556	618	680	741	803	865	927	989	1 050	1 112	1 174	1 236	1 359	1 483
	K22, K22W	1,287	323	404	485	566	647	727	808	889	970	1 051	1 131	1 212	1 293	1 374	1 455	1 535	1 616	1 778	1 940
	K32	1,301	425	532	638	745	851	957	1 064	1 170	1 276	1 383	1 489	1 596	1 702	1 808	1 915	2 021	2 127	2 340	2 553
	K33, K33W	1,287	495	618	742	866	989	1 113	1 237	1 360	1 484	1 608	1 731	1 855	1 979	2 102	2 226	2 350	2 473	2 721	2 968
	K43	1,301	595	744	893	1 042	1 191	1 340	1 489	1 637	1 786	1 935	2 084	2 233	2 382	2 531	2 679	2 828	2 977	3 275	3 573
	K44, K44W	1,287	661	826	991	1 157	1 322	1 487	1 652	1 818	1 983	2 148	2 313	2 478	2 644	2 809	2 974	3 139	3 305	3 635	3 966
	K54	1,301	757	946	1 136	1 325	1 514	1 703	1 893	2 082	2 271	2 460	2 650	2 839	3 028	3 217	3 407	3 596	3 785	4 164	4 542
K55, K55W	1,287	824	1 030	1 236	1 442	1 648	1 854	2 060	2 266	2 472	2 678	2 884	3 090	3 296	3 502	3 708	3 914	4 120	4 531	4 943	

65 / 55 / 20 °C, ($\Delta T=40\text{K}$) 2 600–6 000 mm

Height [mm]	Model	n [-]	Length [mm]																	
			2 600	2 800	3 000	3 200	3 400	3 600	3 800	4 000	4 200	4 400	4 600	4 800	5 000	5 200	5 400	5 600	5 800	6 000
70 mm	K21	1,294	655	705	755	806	856	906	957	1 007	1 057	1 108	1 158	1 208	1 259	1 309	1 359	1 410	1 460	1 510
	K22, K22W	1,305	845	910	975	1 040	1 105	1 170	1 235	1 300	1 365	1 430	1 495	1 560	1 626	1 691	1 756	1 821	1 886	1 951
	K32	1,294	1 126	1 213	1 299	1 386	1 472	1 559	1 646	1 732	1 819	1 905	1 992	2 079	2 165	2 252	2 338	2 425	2 512	2 598
	K33, K33W	1,305	1 294	1 394	1 493	1 593	1 692	1 792	1 891	1 991	2 091	2 190	2 290	2 389	2 489	2 588	2 688	2 787	2 887	2 986
	K43	1,294	1 576	1 697	1 818	1 940	2 061	2 182	2 303	2 424	2 546	2 667	2 788	2 909	3 031	3 152	3 273	3 394	3 515	3 637
	K44, K44W	1,305	1 731	1 865	1 998	2 131	2 264	2 397	2 530	2 664	2 797	2 930	3 063	3 196	3 330	3 463	3 596	3 729	3 862	3 995
	K54	1,294	2 002	2 157	2 311	2 465	2 619	2 773	2 927	3 081	3 235	3 389	3 543	3 697	3 851	4 005	4 159	4 313	4 467	4 621
K55, K55W	1,305	2 137	2 302	2 466	2 631	2 795	2 960	3 124	3 288	3 453	3 617	3 782	3 946	4 111	4 275	4 439	4 604	4 768	4 933	
140 mm	K21	1,296	1 020	1 099	1 177	1 256	1 334	1 413	1 491	1 570	1 648	1 727	1 805	1 884	1 962	2 041	2 119	2 197	2 276	2 354
	K22, K22W	1,299	1 348	1 452	1 556	1 660	1 763	1 867	1 971	2 074	2 178	2 282	2 386	2 489	2 593	2 697	2 801	2 904	3 008	3 112
	K32	1,296	1 758	1 893	2 029	2 164	2 299	2 434	2 570	2 705	2 840	2 975	3 111	3 246	3 381	3 516	3 652	3 787	3 922	4 057
	K33, K33W	1,299	2 062	2 221	2 380	2 538	2 697	2 856	3 014	3 173	3 332	3 490	3 649	3 808	3 966	4 125	4 284	4 442	4 601	4 760
	K43	1,296	2 459	2 648	2 837	3 027	3 216	3 405	3 594	3 783	3 972	4 162	4 351	4 540	4 729	4 918	5 107	5 297	5 486	5 675
	K44, K44W	1,299	2 757	2 969	3 181	3 393	3 605	3 818	4 030	4 242	4 454	4 666	4 878	5 090	5 302	5 514	5 726	5 938	6 151	6 363
	K54	1,296	3 127	3 368	3 608	3 849	4 089	4 330	4 570	4 811	5 051	5 292	5 532	5 773	6 013	6 254	6 494	6 735	6 976	7 216
K55, K55W	1,299	3 436	3 701	3 965	4 229	4 493	4 758	5 022	5 286	5 551	5 815	6 079	6 344	6 608	6 872	7 137	7 401	7 665	7 930	
210 mm	K21	1,299	1 329	1 431	1 533	1 636	1 738	1 840	1 942	2 045	2 147	2 249	2 351	2 453	2 556	2 658	2 760	2 862	2 965	3 067
	K22, K22W	1,293	1 754	1 888	2 023	2 158	2 293	2 428	2 563	2 698	2 833	2 967	3 102	3 237	3 372	3 507	3 642	3 777	3 912	4 047
	K32	1,299	2 288	2 464	2 640	2 816	2 992	3 168	3 344	3 520	3 696	3 872	4 048	4 224	4 400	4 576	4 752	4 928	5 104	5 280
	K33, K33 W	1,293	2 685	2 891	3 098	3 304	3 511	3 717	3 924	4 131	4 337	4 544	4 750	4 957	5 163	5 370	5 576	5 783	5 989	6 196
	K43	1,299	3 201	3 447	3 693	3 939	4 186	4 432	4 678	4 924	5 170	5 417	5 663	5 909	6 155	6 402	6 648	6 894	7 140	7 386
	K44, K44W	1,293	3 587	3 863	4 139	4 415	4 691	4 967	5 242	5 518	5 794	6 070	6 346	6 622	6 898	7 174	7 450	7 726	8 002	8 278
	K54	1,299	4 071	4 384	4 697	5 010	5 323	5 636	5 949	6 262	6 575	6 889	7 202	7 515	7 828	8 141	8 454	8 767	9 080	9 393
K55, K55W	1,293	4 471	4 815	5 159	5 503	5 847	6 191	6 535	6 879	7 223	7 567	7 911	8 255	8 599	8 943	9 287	9 631	9 975	10 319	
280 mm	K21	1,301	1 606	1 730	1 854	1 977	2 101	2 224	2 348	2 471	2 595	2 719	2 842	2 966	3 089	3 213	3 337	3 460	3 584	3 707
	K22, K22W	1,287	2 101	2 263	2 424	2 586	2 748	2 909	3 071	3 233	3 394	3 556								

Heating output of convectors $\Delta T=30\text{ K}$

55 / 45 / 20 °C, ($\Delta T=30\text{K}$) 400–2 400 mm

Height [mm]	Model	n [-]	Length [mm]																		
			400	500	600	700	800	900	1 000	1 100	1 200	1 300	1 400	1 500	1 600	1 700	1 800	1 900	2 000	2 200	2 400
70 mm	K21	1,294	69	87	104	121	139	156	173	191	208	226	243	260	278	295	312	330	347	382	416
	K22, K22W	1,305	89	112	134	156	179	201	223	246	268	290	313	335	357	380	402	424	447	491	536
	K32	1,294	119	149	179	209	239	269	298	328	358	388	418	448	478	507	537	567	597	657	716
	K33, K33W	1,305	137	171	205	239	274	308	342	376	410	445	479	513	547	581	616	650	684	752	821
	K43	1,294	167	209	251	292	334	376	418	459	501	543	585	627	668	710	752	794	835	919	1 003
	K44, K44W	1,305	183	229	274	320	366	412	457	503	549	595	640	686	732	778	823	869	915	1 006	1 098
	K54	1,294	212	265	318	372	425	478	531	584	637	690	743	796	849	902	955	1 008	1 062	1 168	1 274
K55, K55W	1,305	226	282	339	395	452	508	565	621	678	734	791	847	904	960	1 017	1 073	1 130	1 243	1 355	
140 mm	K21	1,296	108	135	162	189	216	243	270	297	324	351	378	405	432	459	487	514	541	595	649
	K22, K22W	1,299	143	178	214	250	286	321	357	393	428	464	500	535	571	607	642	678	714	785	857
	K32	1,296	186	233	279	326	373	419	466	512	559	606	652	699	745	792	838	885	932	1 025	1 118
	K33, K33W	1,299	218	273	328	382	437	491	546	601	655	710	764	819	873	928	983	1 037	1 092	1 201	1 310
	K43	1,296	261	326	391	456	521	586	651	717	782	847	912	977	1 042	1 107	1 173	1 238	1 303	1 433	1 564
	K44, K44W	1,299	292	365	438	511	584	657	730	803	876	949	1 022	1 095	1 168	1 241	1 314	1 387	1 460	1 606	1 751
	K54	1,296	331	414	497	580	663	746	828	911	994	1 077	1 160	1 243	1 325	1 408	1 491	1 574	1 657	1 822	1 988
K55, K55W	1,299	364	455	546	637	728	819	910	1 000	1 091	1 182	1 273	1 364	1 455	1 546	1 637	1 728	1 819	2 001	2 183	
210 mm	K21	1,299	141	176	211	246	281	317	352	387	422	457	492	528	563	598	633	668	704	774	844
	K22, K22W	1,293	186	232	279	325	372	418	465	511	558	604	651	697	744	790	837	883	930	1 023	1 116
	K32	1,299	242	303	363	424	485	545	606	666	727	787	848	908	969	1 030	1 090	1 151	1 211	1 332	1 454
	K33, K33W	1,293	285	356	427	498	569	641	712	783	854	925	997	1 068	1 139	1 210	1 281	1 353	1 424	1 566	1 708
	K43	1,299	339	424	508	593	678	762	847	932	1 017	1 101	1 186	1 271	1 356	1 440	1 525	1 610	1 694	1 864	2 033
	K44, K44W	1,293	380	476	571	666	761	856	951	1 046	1 141	1 236	1 331	1 427	1 522	1 617	1 712	1 807	1 902	2 092	2 283
	K54	1,299	431	539	646	754	862	970	1 077	1 185	1 293	1 401	1 508	1 616	1 724	1 832	1 939	2 047	2 155	2 370	2 586
K55, K55W	1,293	474	593	711	830	948	1 067	1 186	1 304	1 423	1 541	1 660	1 778	1 897	2 015	2 134	2 253	2 371	2 608	2 845	
280 mm	K21	1,301	170	212	255	297	340	382	425	467	510	552	595	637	680	722	765	807	850	935	1 020
	K22, K22W	1,287	223	279	335	391	446	502	558	614	670	726	781	837	893	949	1 005	1 060	1 116	1 228	1 339
	K32	1,301	293	366	439	512	585	658	732	805	878	951	1 024	1 097	1 171	1 244	1 317	1 390	1 463	1 610	1 756
	K33, K33W	1,287	342	427	512	598	683	769	854	939	1 025	1 110	1 196	1 281	1 366	1 452	1 537	1 623	1 708	1 879	2 050
	K43	1,301	410	512	614	717	819	921	1 024	1 126	1 229	1 331	1 433	1 536	1 638	1 741	1 843	1 945	2 048	2 252	2 457
	K44, K44W	1,287	456	571	685	799	913	1 027	1 141	1 255	1 369	1 483	1 597	1 712	1 826	1 940	2 054	2 168	2 282	2 510	2 738
	K54	1,301	521	651	781	911	1 041	1 171	1 302	1 432	1 562	1 692	1 822	1 952	2 083	2 213	2 343	2 473	2 603	2 864	3 124
K55, K55W	1,287	569	711	853	996	1 138	1 280	1 422	1 565	1 707	1 849	1 991	2 134	2 276	2 418	2 560	2 703	2 845	3 129	3 414	

55 / 45 / 20 °C, ($\Delta T=30\text{K}$) 2 600–6 000 mm

Height [mm]	Model	n [-]	Length [mm]																	
			2 600	2 800	3 000	3 200	3 400	3 600	3 800	4 000	4 200	4 400	4 600	4 800	5 000	5 200	5 400	5 600	5 800	6 000
70 mm	K21	1,294	451	486	520	555	590	625	659	694	729	763	798	833	867	902	937	972	1 006	1 041
	K22, K22W	1,305	581	625	670	715	759	804	849	893	938	983	1 027	1 072	1 117	1 161	1 206	1 251	1 295	1 340
	K32	1,294	776	836	895	955	1 015	1 074	1 134	1 194	1 253	1 313	1 373	1 433	1 492	1 552	1 612	1 671	1 731	1 791
	K33, K33W	1,305	889	957	1 026	1 094	1 163	1 231	1 299	1 368	1 436	1 505	1 573	1 641	1 710	1 778	1 847	1 915	1 983	2 052
	K43	1,294	1 086	1 170	1 253	1 337	1 420	1 504	1 587	1 671	1 754	1 838	1 921	2 005	2 089	2 172	2 256	2 339	2 423	2 506
	K44, K44W	1,305	1 189	1 281	1 372	1 464	1 555	1 647	1 738	1 830	1 921	2 013	2 104	2 196	2 287	2 379	2 470	2 562	2 653	2 745
	K54	1,294	1 380	1 486	1 592	1 699	1 805	1 911	2 017	2 123	2 229	2 335	2 442	2 548	2 654	2 760	2 866	2 972	3 079	3 185
K55, K55W	1,305	1 468	1 581	1 694	1 807	1 920	2 033	2 146	2 259	2 372	2 485	2 598	2 711	2 824	2 937	3 050	3 163	3 276	3 389	
140 mm	K21	1,296	703	757	811	865	919	973	1 027	1 081	1 135	1 189	1 243	1 297	1 351	1 405	1 460	1 514	1 568	1 622
	K22, K22W	1,299	928	999	1 071	1 142	1 213	1 285	1 356	1 428	1 499	1 570	1 642	1 713	1 785	1 856	1 927	1 999	2 070	2 141
	K32	1,296	1 211	1 304	1 397	1 490	1 584	1 677	1 770	1 863	1 956	2 049	2 143	2 236	2 329	2 422	2 515	2 608	2 701	2 795
	K33, K33W	1,299	1 419	1 529	1 638	1 747	1 856	1 965	2 074	2 184	2 293	2 402	2 511	2 620	2 730	2 839	2 948	3 057	3 166	3 275
	K43	1,296	1 694	1 824	1 954	2 085	2 215	2 345	2 476	2 606	2 736	2 866	2 997	3 127	3 257	3 388	3 518	3 648	3 778	3 909
	K44, K44W	1,299	1 897	2 043	2 189	2 335	2 481	2 627	2 773	2 919	3 065	3 211	3 357	3 503	3 649	3 795	3 941	4 087	4 233	4 379
	K54	1,296	2 154	2 319	2 485	2 651	2 816	2 982	3 148	3 314	3 479	3 645	3 811	3 976	4 142	4 308	4 473	4 639	4 805	4 970
K55, K55W	1,299	2 365	2 547	2 729	2 910	3 092	3 274	3 456	3 638	3 820	4 002	4 184	4 366	4 548	4 729	4 911	5 093	5 275	5 457	
210 mm	K21	1,299	915	985	1 055	1 126	1 196	1 266	1 337	1 407	1 477	1 548	1 618	1 688	1 759	1 829	1 899	1 970	2 040	2 111
	K22, K22W	1,293	1 209	1 302	1 395	1 488	1 581	1 674	1 767	1 860	1 953	2 046	2 139	2 232	2 325	2 418	2 511	2 604	2 697	2 790
	K32	1,299	1 575	1 696	1 817	1 938	2 059	2 180	2 301	2 423	2 544	2 665	2 786	2 907	3 028	3 149	3 271	3 392	3 513	3 634
	K33, K33W	1,293	1 851	1 993	2 136	2 278	2 420	2 563	2 705	2 847	2 990	3 132	3 275	3 417	3 559	3 702	3 844	3 986	4 129	4 271
	K43	1,299	2 203	2 372	2 542	2 711	2 880	3 050	3 219	3 389	3 558	3 728	3 897	4 067	4 236	4 405	4 575	4 744	4 914	5 083
	K44, K44W	1,293	2 473	2 663	2 853	3 043	3 234	3 424	3 614	3 804	3 994	4 185	4 375	4 565	4 755	4 945	5 136	5 326	5 516	5 706
	K54	1,299	2 801	3 017	3 232	3 448	3 663	3 879	4 094	4 310	4 525	4 741	4 956	5 172	5 387	5 603	5 818	6 033	6 249	6 464
K55, K55W	1,293	3 083	3 320	3 557	3 794	4 031	4 268	4 505	4 742	4 979	5 217	5 454	5 691	5 928	6 165	6 402	6 639	6 876	7 114	
280 mm	K21	1,301	1 105	1 190	1 275	1 360	1 445	1 530	1 615	1 700	1 785	1 870	1 955	2 040	2 125	2 210	2 295	2 380	2 465	2 550
	K22, K22W	1,287	1 451	1 563	1 674	1 786	1 897	2 009	2 121	2 232	2 344	2 456	2 567	2 679	2 790	2 902	3 014	3 125	3 237	3 348
	K32	1,301	1 902	2 048	2 195	2 341	2 487	2 634	2 780	2 926	3 073	3 219	3 365	3 512	3 658	3 804	3 951	4 097	4 243	4 390
	K33, K33W																			

Floor stands and wall brackets

The supplied stands and brackets allow for the unit to be fixed securely to the wall or floor. The mounting system has been designed to provide an adequate support to the considerable weight of the Exact convectors. The load-bearing capacity of the substrate is equally important. Possible solutions may include structure reinforcement or the use of additional supports. The anchoring system is flexible and can be tailor-made to meet customer-specified requirements regarding clearance or design modifications. Please direct all your requests to the ISAN Technical Department. The floor stands and wall brackets are not supplied with the heating units. They are packaged and shipped separately as optional accessories.

Standard stands – Subtle, Tall and Block

The stands allow for correct and safe positioning of each unit in the interior. While supporting the radiant convectors, they ensure proper anchoring and resistance of the installed unit during normal use and stress. At the same time, the stands complete the design aesthetic. The near-invisible and slim Subtle stands allow the robustness of the metal body to stand out. The Block stands are prominent, forming an integral component of the overall appearance. They provide a visible and solid connection to the floor structure. The Tall stands are the preferred choice for commercial buildings with double flooring. They are of sufficient height and strength to support the unit above ground, even when anchored to the underlying rough concrete floor.

Flat floor stands Subtle

Identification coding: F2

Flat floor stands made of strip steel. Each floor stand includes a plastic cover and fastening components with a locking mechanism to prevent the unit from disengaging. The convector type must be fully specified when placing an order.

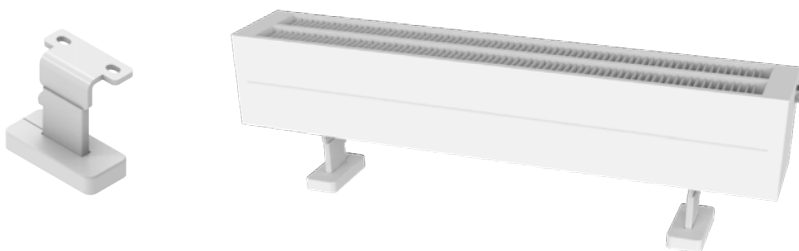

Covers

Available plastic covers 110 × 50 mm

Unless the order specifies otherwise, the covers are automatically selected to match the colour of the convector.



RAL 9016



RAL 9006



RAL 7024



RAL 9005

The convector height above ground when mounted on floor stands: **100 mm**

Double flooring floor stands Tall

Identification coding: F6

Installation into bonded or sandwich (double) floors requires the use of double flooring stands. The standard clear height of the floor stands is 450 mm, which can be as required on site to conform to the floor composition.

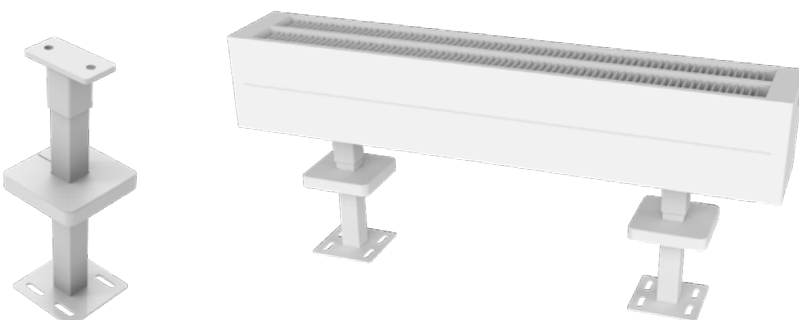

Covers

Available plastic covers 110 x 110 mm

Unless the order specifies otherwise, the covers are automatically selected to match the colour of the convector.



RAL 9016



RAL 9006



RAL 7024



RAL 9005

The maximum stand height is **450 mm**; can be adjusted on site

Floor stands Block

Identification coding: S1

A compact unit with steel column feet. The Block floor stands require an alternative mounting arrangement on the convector body; the order specify which unit the stands are for. In the case of a connection with the valve placed inside the foot (EF, FE, EE, FF connection options), one foot will an opening to facilitate installation of the thermostatic valve and the thermostatic head. Use the Z-TD001 valve to ensure proper alignment with the opening.

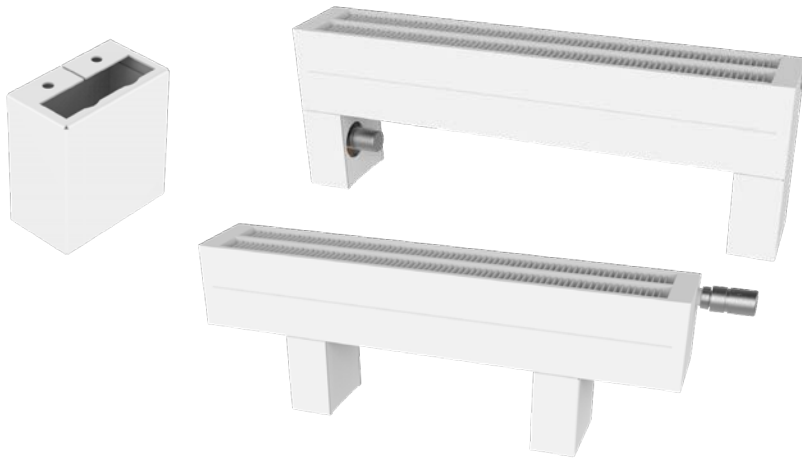

The height of the stand is **140 mm**.

Notice

For VR VL valve connections where the heating medium lines on the side are 50 mm apart, the Block stands are positioned 150 mm from the edge of the convector.

Floor stands Frame

Identification coding: P1

Design stands made from steel strip profiles provide a stylish and stable support for the convector. They are made of quality steel strip profile and form an elegant stand under the convector, which ensures not only a firm anchorage, but also a modern look. Their minimalist shape naturally harmonizes with the clean lines of the convector and does not disrupt the design of the space.

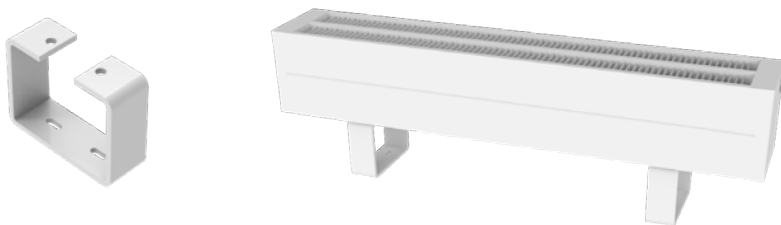

The height of the stand is **100 mm**.

Note

If the project requires a specific position of the radiant convector, it is possible to prepare a custom-made Frame stand height.

Convactor mounting



The number of floor stands as per the unit length

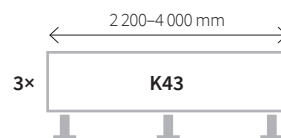

The number of floor stands

Model	2	3	4	5
K21, K22, K22W				
K32, K33, K33W	400-2000	2200-4000	4200-6000	-
K43, K44, K44W				
K54, K55, K55W	400-1000	1100-2000	2200-4000	4200-6000

RIGID R1, R2, R3 stands meeting the VDI 6036 Class 3 criteria (for installations with strict anchoring requirements).

The stands are designed for use in public environments where the heating unit is exposed to greater stress and shocks. People leaning against or sitting/placing objects on the radiators is expected. Collisions with cleaning machines or luggage trolleys may also occur. In school settings, gross negligence and sometimes intentional abuse cannot be ruled out. In sports facilities, the units can be subjected to sudden impacts from multiple people.

After installation, the unit must be able to maintain the correct position to avoid any damage to the heating system connection or other components.

- airports, train stations, barracks
- schools, sports facilities, youth centers
- swimming pools, churches
- rest areas, public toilets
- correctional facilities, psychiatric facilities
- hallways with escape routes

Fixed low stand Rigid R1

Identification coding: R1

The rigid design guarantees secure mounting of the convector. The stands are bolted to the convector.

Design fixed rigid stand
Material thick-walled strip steel

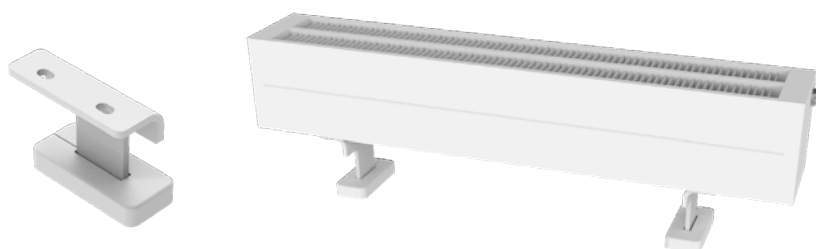

Covers

Available plastic covers 110 × 50 mm

Unless the order specifies otherwise, the covers are automatically selected to match the colour of the convector.



RAL 9016



RAL 9006



RAL 7024



RAL 9005

Stand height: **100 mm**

Adjustable stand Rigid R2

Identification coding: R2

The rigid design with two support sections allows for installation on uneven surfaces. The stands are bolted to the convector.

Design optional 10-mm height adjustment
Material steel, doubled square sections

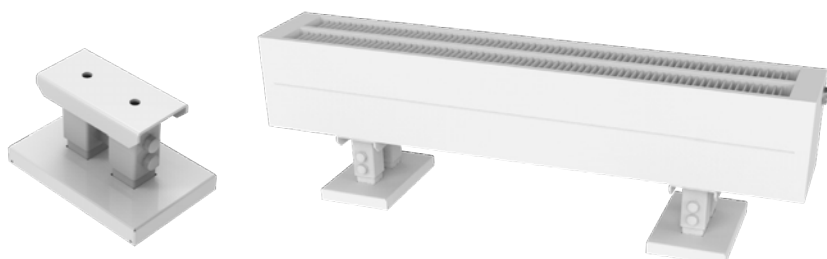

Covers

Metal covers 170 × 110 mm

(to be ordered separately)

The steel covers are supplied in the colour of the convector

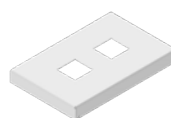

C1 cover

Fitted on the stand during convector installation
Code: O11963-COV-01...

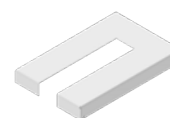

C2 cover

Can be fitted after installation is complete
Code: O11963-COV-02...

Stand height: **100-110 mm**

High double flooring stand Rigid R3

Identification coding: R3

The lower section of the stand can be cut to the required height to fit the double flooring on site. A minimum spacing of 40 mm must be maintained between the final and rough floor.

Design for double flooring installation
Material reinforced doubled square sections

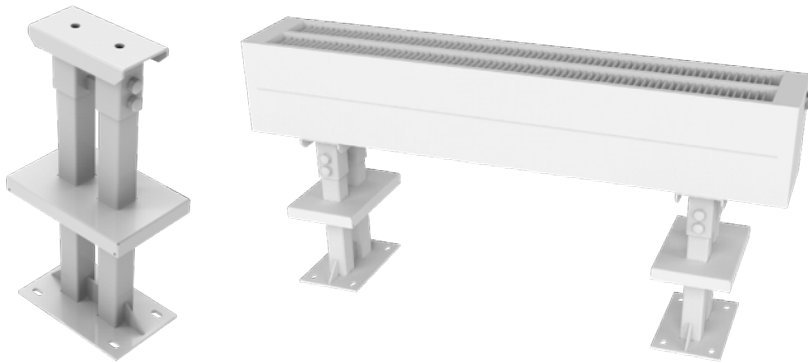

Covers

Metal covers 170 × 110 mm
 (to be ordered separately)

The steel covers are supplied in the colour of the convector

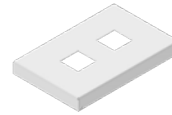

C1 cover

Fitted on the stand during convector installation
 Code: O11963-COV-01...

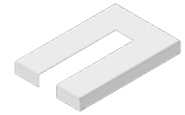

C2 cover

Can be fitted after installation is complete
 Code: O11963-COV-02...

The maximum stand height is **450 mm**; can be adjusted on site

Note: The stand is not compatible with the K21 and K22 models.

Convector mounting

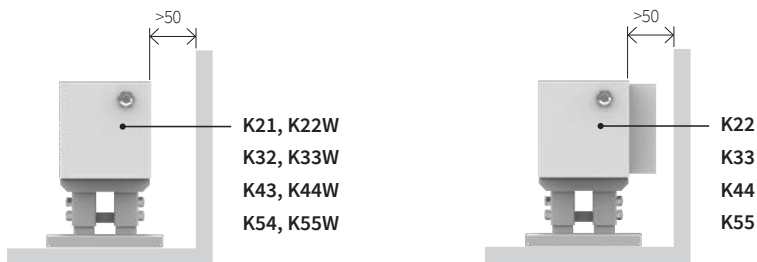

The number of floor stands as per the unit length

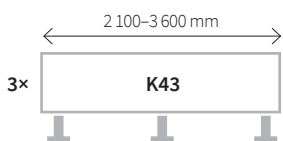

The number of floor stands

Model	2	3	4	5	6
K21, K22, K22W					
K32, K33, K33W	500-2000	2100-3600	3700-4800	4900-6000	-
K43, K44, K44W					
K54, K55, K55W	500-2000	2100-3200	3300-4400	4500-5500	5600-6000

Wall brackets

Wall brackets Subtle

Identification coding: W2

Flat wall-mounting brackets made of thick strip steel. Each wall bracket includes fastening components with a locking mechanism to prevent the unit from sliding out. The type must be fully specified when placing an order.



Wall-mounting brackets

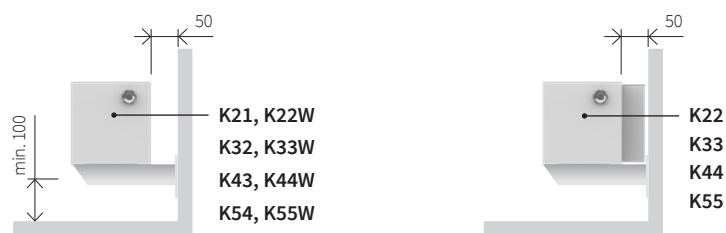

The number of wall brackets as per the unit length

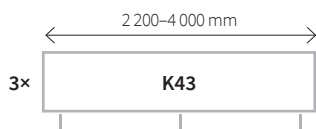

The number of wall brackets

Model	2	3	4	5
K21, K22, K22W				
K32, K33, K33W	400-2000	2200-4000	4200-6000	-
K43, K44, K44W				
K54, K55, K55W	400-1000	1100-2000	2200-4000	4200-6000

Accessories

Top grille

The convectors are supplied without a grille as standard. The exposed transition surface finning can be covered with an upper grille. The grille matches the color of the convector.

Linear grille

Identification coding: L

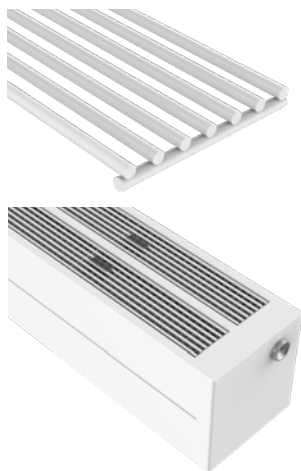

Grille with rectangular holes

Identification coding: D

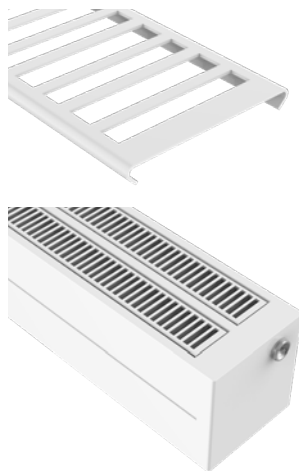

Grille with round holes

Identification coding: V

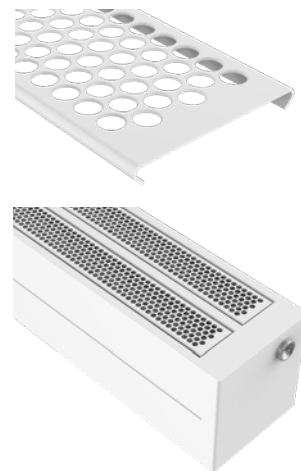

Magnetic rail

To facilitate preheating or cloth drying the convector can be fitted with designer accessories such as magnetic rails and hooks. The components are available in a chrome finish.

A magnetic rail in three length variations (sized up to the outer edges)



Description	Identification
Rail 260 mm	015MD80-02
Rail 430 mm	015MD80-03
Rail 550 mm	015MD80-04



Magnetic hook

A magnetic hook with $\varnothing 54$ mm base.



Description	Identification
Magnetic hook	015MD80-01

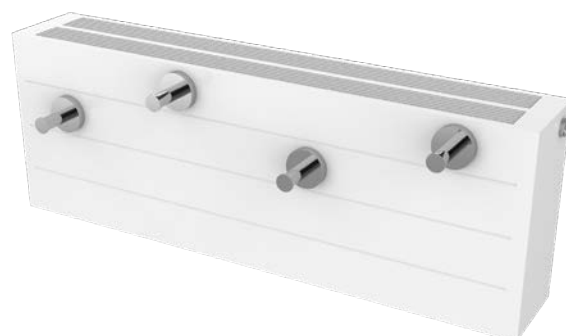

Heating System Connection

To ensure correct connection of the unit, specify the order code of the selected convector design. The basic identification consists of letter codes in the following layout:

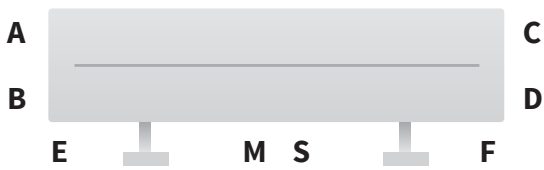

Connection types

AB one-sided



CD one-sided



AD diagonal



CB diagonal



BD bottom continuous



DB bottom continuous



AC continuous



CA continuous

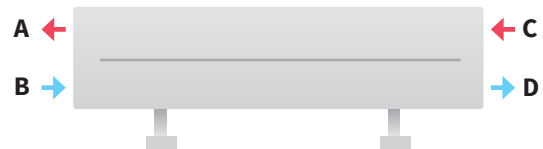

EF bottom



FE bottom



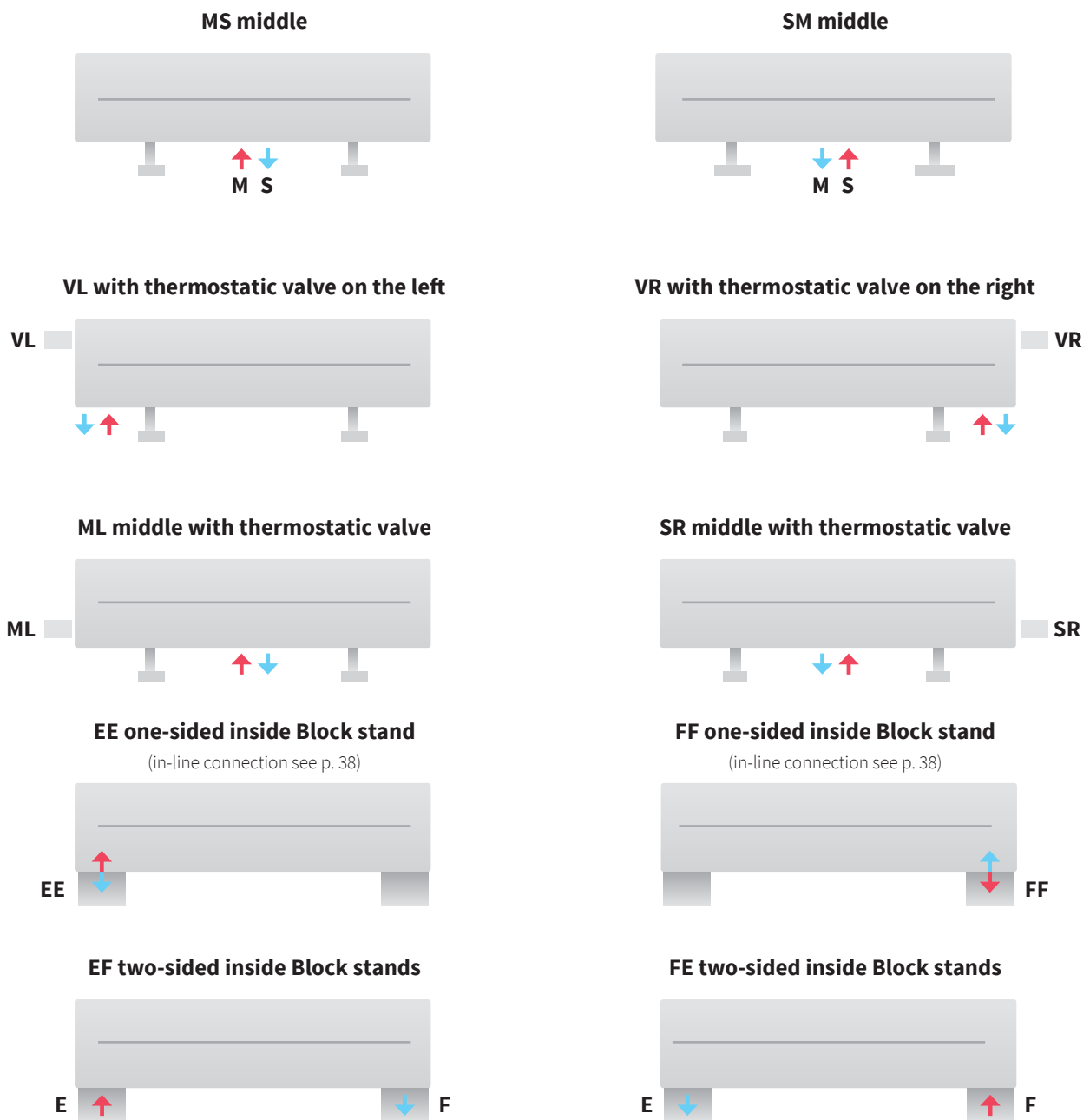

Connection thread

High-performance units with greater heating medium flows require a large-diameter connection thread. To meet this requirement, we offer radiators with a G3/4" connection thread (instead of the standard G1/2"). This option is also recommended when connecting multiple convectors in a line, e.g. AC + AC + AB (see page 34).

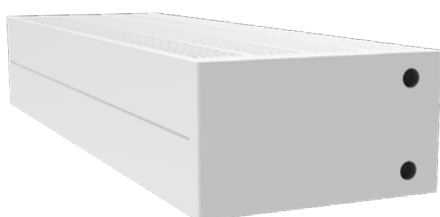

G1/2" connection thread (standard)



G3/4" connection thread

Thermostatic Packs

Thermostatic set

Angular – triax



illustration image

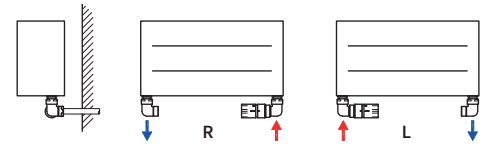

Pack nr. 101L / white / left / Code: O37BUCL101
Pack nr. 101R / white / right / Code: O37BUCR101
Connection to copper pipes Ø 15 mm
 Thermostatic head / white
 Angular thermostatic valve and lockshield valve / white
 Clamping fittings for copper pipes / chrome

Pack nr. 103L / chrome / left / Code: O37CUCL103
Pack nr. 103R / chrome / right / Code: O37CUCR103
Connection to copper pipes Ø 15 mm
 Thermostatic head / chrome
 Angular thermostatic valve and lockshield valve / chrome
 Clamping fittings for copper pipes / chrome

Pack nr. 105L / INOX / left / Code: O37NUCL105
Pack nr. 105R / INOX / right / Code: O37NUCR105
Connection to copper pipes Ø 15 mm
 Thermostatic head / INOX
 Angular thermostatic valve and lockshield valve / INOX
 Clamping fittings for copper pipes / INOX

Pack nr. 102L / white / left / Code: O37BUAL102
Pack nr. 102R / white / right / Code: O37BUAR102
Connection to Al/PE-X, Al/PERT pipes Ø 16×2 mm
 Thermostatic head / white
 Angular thermostatic valve and lockshield valve / white
 Clamping fittings for Al/PE-X, Al/PERT / chrome

Pack nr. 104L / chrome / left / Code: O37CUAL104
Pack nr. 104R / chrome / right / Code: O37CUAR104
Connection to Al/PE-X, Al/PERT pipes Ø 16×2 mm
 Thermostatic head / chrome
 Angular thermostatic valve and lockshield valve / chrome
 Clamping fittings for Al/PE-X, Al/PERT / chrome

Pack nr. 106L / INOX / left / Code: O37NUAL106
Pack nr. 106R / INOX / right / Code: O37NUAR106
Connection to Al/PE-X, Al/PERT pipes Ø 16×2 mm
 Thermostatic head / INOX
 Angular thermostatic valve and lockshield valve / INOX
 Clamping fittings for Al/PE-X, Al/PERT / INOX

Thermostatic set

Direct



illustration image

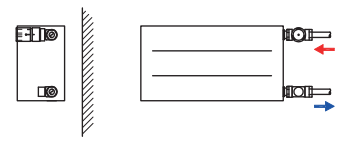

Pack nr. 107 / white / Code: O37BPC-107
Connection to copper pipes Ø 15 mm
 Thermostatic head / white
 Direct thermostatic valve and lockshield valve / white
 Clamping fittings for copper pipes / chrome

Pack nr. 109 / chrome / Code: O37CPC-109
Connection to copper pipes Ø 15 mm
 Thermostatic head / chrome
 Direct thermostatic valve and lockshield valve / chrome
 Clamping fittings for copper pipes / chrome

Pack nr. 111 / INOX / Code: O37NPC-111
Connection to copper pipes Ø 15 mm
 Thermostatic head / INOX
 Set – Direct thermostatic valve and lockshield valve / INOX
 Clamping fittings for copper pipes / INOX

Pack nr. 108 / white / Code: O37BPA-108
Connection to Al/PE-X, Al/PERT pipes Ø 16×2 mm
 Thermostatic head / white
 Direct thermostatic valve and lockshield valve / white
 Clamping fittings for Al/PE-X, Al/PERT / chrome

Pack nr. 110 / chrome / Code: O37CPA-110
Connection to Al/PE-X, Al/PERT pipes Ø 16×2 mm
 Thermostatic head / chrome
 Direct thermostatic valve and lockshield valve / chrome
 Clamping fittings for Al/PE-X, Al/PERT / chrome

Pack nr. 112 / INOX / Code: O37NPA-112
Connection to Al/PE-X, Al/PERT pipes Ø 16×2 mm
 Thermostatic head / INOX
 Direct thermostatic valve and lockshield valve / INOX
 Clamping fittings for Al/PE-X, Al/PERT / INOX

Thermostatic set

Corner



illustration image

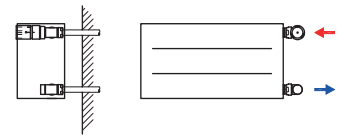

Pack nr. 113 / white / Code: O37BRC-113
Connection to copper pipes Ø 15 mm
 Thermostatic head / white
 Corner thermostatic valve and lockshield valve / white
 Clamping fittings for copper pipes / chrome

Pack nr. 115 / chrome / Code: O37CRC-115
Connection to copper pipes Ø 15 mm
 Thermostatic head / chrome
 Corner thermostatic valve and lockshield valve / chrome
 Clamping fittings for copper pipes / chrome

Pack nr. 117 / INOX / Code: O37NRC-117
Connection to copper pipes Ø 15 mm
 Thermostatic head / INOX
 Corner thermostatic valve and lockshield valve / INOX
 Clamping fittings for copper pipes / INOX

Pack nr. 114 / white / Code: O37BRA-114
Connection to Al/PE-X, Al/PERT pipes Ø 16×2 mm
 Thermostatic head / white
 Corner thermostatic valve and lockshield valve / white
 Clamping fittings for Al/PE-X, Al/PERT / chrome

Pack nr. 116 / chrome / Code: O37CRA-116
Connection to Al/PE-X, Al/PERT pipes Ø 16×2 mm
 Thermostatic head / chrome
 Corner thermostatic valve and lockshield valve / chrome
 Clamping fittings for Al/PE-X, Al/PERT / chrome

Pack nr. 118 / INOX / Code: O37NRA-118
Connection to Al/PE-X, Al/PERT pipes Ø 16×2 mm
 Thermostatic head / INOX
 Corner thermostatic valve and lockshield valve / INOX
 Clamping fittings for Al/PE-X, Al/PERT / INOX

Thermostatic valve

Corner – middle



illustration image

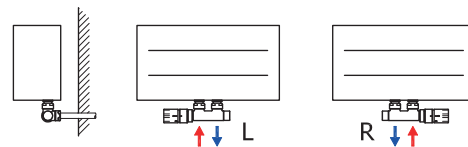

Pack nr. 119L / white / left / Code: O37BWCL119
Pack nr. 119R / white / right / Code: O37BWC119
 Connection to copper pipes Ø 15 mm
 Thermostatic head / white
 Corner thermostatic valve and lockshield valve / white
 Clamping fittings for copper pipes / chrome

Pack nr. 120L / white / left / Code: O37BWAL120
Pack nr. 120R / white / right / Code: O37BWAR120
 Connection to Al/PE-X, Al/PERT pipes Ø 16x2 mm
 Thermostatic head / white
 Corner thermostatic valve and lockshield valve / white
 Clamping fittings for Al/PE-X, Al/PERT / chrome

Pack nr. 121L / chrome / left / Code: O37CWCL121
Pack nr. 121R / chrome / right / Code: O37CWC121
 Connection to copper pipes Ø 15 mm
 Thermostatic head / chrome
 Corner thermostatic valve and lockshield valve / chrome
 Clamping fittings for copper pipes / chrome

Pack nr. 122L / chrome / left / Code: O37CWAL122
Pack nr. 122R / chrome / right / Code: O37CWAR122
 Connection to Al/PE-X, Al/PERT pipes Ø 16x2 mm
 Thermostatic head / chrome
 Corner thermostatic valve and lockshield valve / chrome
 Clamping fittings for Al/PE-X, Al/PERT / chrome

Pack nr. 123L / INOX / left / Code: O37NWCL123
Pack nr. 123R / INOX / right / Code: O37NWC123
 Connection to copper pipes Ø 15 mm
 Thermostatic head / INOX
 Corner thermostatic valve and lockshield valve / INOX
 Clamping fittings for copper pipes / INOX

Pack nr. 124L / INOX / left / Code: O37NWAL124
Pack nr. 124R / INOX / right / Code: O37NWAR124
 Connection to Al/PE-X, Al/PERT pipes Ø 16x2 mm
 Thermostatic head / INOX
 Corner thermostatic valve and lockshield valve / INOX
 Clamping fittings for Al/PE-X, Al/PERT / INOX

Pack nr. 219L / black / left / Code: O37SWCL219
Pack nr. 219R / black / right / Code: O37SWC219
 Connection to copper pipes Ø 15 mm
 Thermostatic head / black
 Corner thermostatic valve and lockshield valve / black
 Clamping fittings for copper pipes / chrome

Pack nr. 220L / black / left / Code: O37SWAL220
Pack nr. 220R / black / right / Code: O37SWAR220
 Connection to Al/PE-X, Al/PERT pipes Ø 16x2 mm
 Thermostatic head / black
 Corner thermostatic valve and lockshield valve / black
 Clamping fittings for Al/PE-X Al/PERT / chrome

Pack nr. 221L / black matt / left / Code: O39SWCL221
Pack nr. 221R / black matt / right / Code: O39SWC221
 Connection to copper pipes Ø 15 mm
 Thermostatic head / black matt
 Corner thermostatic valve and lockshield valve / black matt
 Clamping fittings for copper pipes / chrome

Pack nr. 222L / black matt / left / Code: O39SWAL222
Pack nr. 222R / black matt / right / Code: O39SWAR222
 Připojení na Al/PEX, Al/PERT trubky Ø 16x2 mm
 Thermostatic head / black matt
 Corner thermostatic valve and lockshield valve / black matt
 Clamping fittings for Al/PE-X Al/PERT / chrome

Thermostatic valve

Direct – middle



illustration image

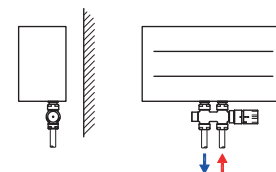

Pack nr. 125 / white / Code: O37BFC-125
 Connection to copper pipes Ø 15 mm
 Thermostatic head / white
 Direct thermostatic valve and lockshield valve / white
 Clamping fittings for copper pipes / chrome

Pack nr. 126 / white / Code: O37BFA-126
 Connection to Al/PE-X, Al/PERT pipes Ø 16x2 mm
 Thermostatic head / white
 Direct thermostatic valve and lockshield valve / white
 Clamping fittings for Al/PE-X, Al/PERT / chrome

Pack nr. 127 / chrome / Code: O37CFC-127
 Connection to copper pipes Ø 15 mm
 Thermostatic head / chrome
 Direct thermostatic valve and lockshield valve / chrome
 Clamping fittings for copper pipes / chrome

Pack nr. 128 / chrome / Code: O37CFA-128
 Connection to Al/PE-X, Al/PERT pipes Ø 16x2 mm
 Thermostatic head / chrome
 Direct thermostatic valve and lockshield valve / chrome
 Clamping fittings for Al/PE-X, Al/PERT / chrome

Pack nr. 129 / INOX / Code: O37NFC-129
 Connection to copper pipes Ø 15 mm
 Thermostatic head / INOX
 Direct thermostatic valve and lockshield valve / INOX
 Clamping fittings for copper pipes / INOX

Pack nr. 130 / INOX / Code: O37NFA-130
 Connection to Al/PE-X, Al/PERT pipes Ø 16x2 mm
 Thermostatic head / INOX
 Direct thermostatic valve and lockshield valve / INOX
 Clamping fittings for Al/PE-X, Al/PERT / INOX

Thermostatic valve

Universal – middle



illustration image

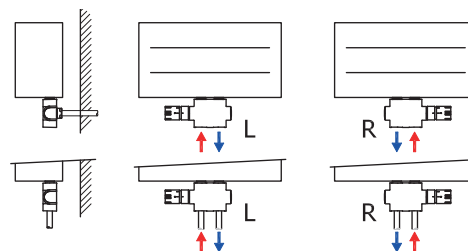

Pack nr. 131L / white / left / Code: O37BUCL131
Pack nr. 131R / white / right / Code: O37BUC131
 Connection to copper pipes Ø 15 mm
 Thermostatic head / white
 Universal centre thermostatic valve and lockshield valve / white
 Clamping fittings for copper pipes / chrome

Pack nr. 132L / white / left / Code: O37BUAL132
Pack nr. 132R / white / right / Code: O37BUAR132
 Connection to Al/PE-X, Al/PERT pipes Ø 16x2 mm
 Thermostatic head / white
 Universal centre thermostatic valve and lockshield valve / white
 Clamping fittings for Al/PE-X, Al/PERT / chrome

Pack nr. 133L / chrome / left / Code: O37CUCL133
Pack nr. 133R / chrome / right / Code: O37CUC133
 Connection to copper pipes Ø 15 mm
 Thermostatic head / chrome
 Universal centre thermostatic valve and lockshield valve / chrome
 Clamping fittings for copper pipes / chrome

Pack nr. 134L / chrome / left / Code: O37CUAL134
Pack nr. 134R / chrome / right / Code: O37CUAR134
 Connection to Al/PE-X, Al/PERT pipes Ø 16x2 mm
 Thermostatic head / chrome
 Universal centre thermostatic valve and lockshield valve / chrome
 Clamping fittings for Al/PE-X, Al/PERT / chrome

LockShield set

corner



illustration image

Pack nr. 181 / white / Code: O37BRC-181

Connection to copper pipes Ø 15 mm

Thermostatic head / white
2 × corner lockshield valve / white
Clamping fittings for copper pipes / chrome

Pack nr. 182 / white / Code: O37BRA-182

Connection to Al/PE-X, Al/PERT pipes Ø 16×2 mm

Thermostatic head / white
2 × corner lockshield valve / white
Clamping fittings for Al/PE-X, Al/PERT / chrome

Pack nr. 183 / chrome / Code: O37CRC-183

Connection to copper pipes Ø 15 mm

Thermostatic head / chrome
2 × corner lockshield valve / chrome
Clamping fittings for copper pipes / chrome

Pack nr. 184 / chrome / Code: O37CRA-184

Connection to Al/PE-X, Al/PERT pipes Ø 16×2 mm

Thermostatic head / chrome
2 × corner lockshield valve / chrome
Clamping fittings for Al/PE-X, Al/PERT / chrome

Pack nr. 185 / INOX / Code: O37NRC-185

Connection to copper pipes Ø 15 mm

Thermostatic head / INOX
2 × corner lockshield valve / INOX
Clamping fittings for copper pipes / INOX

Pack nr. 186 / INOX / Code: O37NRA-186

Connection to Al/PE-X, Al/PERT pipes Ø 16×2 mm

Thermostatic head / INOX
2 × corner lockshield valve / INOX
Clamping fittings for Al/PE-X, Al/PERT / INOX

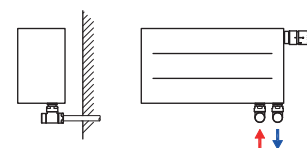

LockShield set

direct



illustration image

Pack nr. 187 / white / Code: O37BPC-187

Connection to copper pipes Ø 15 mm

Thermostatic head / white
2 × direct lockshield valve / white
Clamping fittings for copper pipes / chrome

Pack nr. 188 / white / Code: O37BPA-188

Connection to Al/PE-X, Al/PERT pipes Ø 16×2 mm

Thermostatic head / white
2 × direct lockshield valve / white
Clamping fittings for Al/PE-X, Al/PERT / chrome

Pack nr. 189 / chrome / Code: O37CPC-189

Connection to copper pipes Ø 15 mm

Thermostatic head / chrome
2 × direct lockshield valve / chrome
Clamping fittings for copper pipes / chrome

Pack nr. 190 / chrome / Code: O37CPA-190

Connection to Al/PE-X, Al/PERT pipes Ø 16×2 mm

Thermostatic head / chrome
2 × direct lockshield valve / chrome
Clamping fittings for Al/PE-X, Al/PERT / chrome

Pack nr. 191 / INOX / Code: O37NPC-191

Connection to copper pipes Ø 15 mm

Thermostatic head / INOX
2 × direct lockshield valve / INOX
Clamping fittings for copper pipes / INOX

Pack nr. 192 / INOX / Code: O37NPA-192

Connection to Al/PE-X, Al/PERT pipes Ø 16×2 mm

Thermostatic head / INOX
2 × direct lockshield valve / INOX
Clamping fittings for Al/PE-X, Al/PERT / INOX

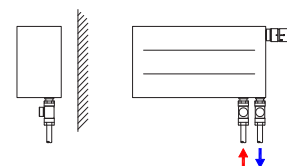

A separate thermostatic head



White

Code: 484111350



Chrome

Code: 484111360



INOX

Code: 484111370



Black gloss

Code: 484000920



Black matt

Code: 484000936

A thermostatic valve and fittings for the Block floor stands

Z-TD001 - Thermostatic valve for convector inlet

Parameters

- Size: DN15, NF standard
- Connecting thread: M30×1,5 mm
- Max. operating temperature 120 °C
- Max. operating pressure PN10
- Option to change pre-setting of kv-value
- kv value (m³/h) range 0.10-0.89
- kv value (m³/h) for zone 2K 0.52
- Parameters identical to the Siemens VDN215 valve



Z-TD001
direct thermostatic valve

Z-RD001 - LockShield valve connection to the convector outlet

Parameters

- Size: DN15
- Value kvs
- direct 0.30-1.80
- corner 0.30-3.00
- Max. operating temperature: 110 °C
- Max. operating overpressure: 10 bar



Z-RD001
direct screw connection

T - Speed	0,5	1	1,5	2	2,5	3	3,5	4	5	6	Max.
Kv (m ³ /h) - straight type	0,3	0,55	0,75	0,91	1,05	1,25	1,33	1,4	1,6	1,7	1,8
Kv (m ³ /h) - angled type	0,2	0,29	0,4	0,5	0,69	0,8	1	1,2	1,55	1,9	2,2

Convector Parameters

Heating medium volume

The reference heating medium volume inside the convector [l / m]

Height/Model	K21	K22, K22W	K32	K33, K33W	K43	K44, K44W	K54	K55, K55W
70 mm	1,2	1,2	1,8	1,8	2,5	2,5	3,2	3,2
140 mm	2,3	2,3	3,7	3,7	5,0	5,0	6,4	6,4
210 mm	3,5	3,5	5,5	5,5	7,6	7,6	9,6	9,6
280 mm	4,7	4,7	7,4	7,4	10,1	10,1	12,8	12,8

Weight specifications

Reference convector weight data [kg/m]

Height [mm]	Model	Length [mm]											
		500	1000	1500	2000	2500	3000	3500	4000	4500	5000	5500	6000
70 mm	K21	3	6	8	11	13	16	18	21	24	26	29	31
	K22	4	7	10	13	16	19	22	25	28	31	35	38
	K22W, K32	5	9	13	17	22	26	30	34	38	42	46	50
	K33-	6	10	15	19	24	29	33	38	43	47	52	57
	K33W, K43	7	13	19	24	30	36	41	47	53	58	64	69
	K44-	8	14	20	26	32	39	45	51	57	63	70	76
	K44W, K54	9	16	24	31	38	45	53	60	67	74	81	88
	K55-	10	17	25	33	41	48	56	64	72	79	87	95
	K55W	11	20	29	37	46	55	64	72	81	90	99	107
140 mm	K21	6	11	17	22	27	32	37	43	48	53	58	64
	K22	7	14	20	26	33	39	46	52	59	65	71	78
	K22W, K32	10	19	27	35	44	52	61	69	78	86	95	103
	K33-	11	21	30	40	50	59	69	79	88	98	108	117
	K33W, K43	14	26	38	49	61	72	84	96	107	119	131	142
	K44-	15	28	41	54	67	79	92	105	118	131	144	156
	K44W, K54	18	33	48	63	78	92	107	122	137	152	167	182
	K55-	19	35	51	67	83	99	116	131	148	164	180	196
	K55W	22	40	58	76	94	112	130	148	167	185	203	221
210 mm	K21	9	17	25	33	41	49	56	64	72	80	88	96
	K22	11	20	30	40	50	59	69	79	89	99	108	118
	K22W, K32	15	28	41	53	66	79	92	105	117	130	143	156
	K33-	17	31	46	60	75	90	104	119	134	148	163	178
	K33W, K43	21	39	56	74	92	109	127	145	162	180	198	215
	K44-	23	42	62	81	101	120	140	159	179	198	218	237
	K44W, K54	27	49	72	95	117	140	162	185	207	230	252	275
	K55-	28	53	77	101	126	150	175	199	224	248	272	297
	K55W	33	60	88	115	142	170	197	224	252	279	307	334
280 mm	K21	12	23	33	44	54	65	75	86	97	107	118	128
	K22	14	27	40	53	67	80	93	106	119	132	145	158
	K22W, K32	20	37	54	71	89	106	123	140	157	174	191	208
	K33-	22	42	61	81	101	120	140	159	179	199	219	238
	K33W, K43	28	52	75	99	123	146	170	194	217	241	265	288
	K44-	30	56	82	108	135	161	187	213	240	266	292	318
	K44W, K54	36	66	96	126	157	187	217	247	278	308	338	368
	K55-	38	70	103	136	169	201	234	267	300	332	365	398
	K55W	44	80	117	154	191	227	264	301	338	374	411	448

Note: the table applies to empty 6 bar units / to calculate the weight of the 10 bar versions multiply the 6 bar by 1.2

Convector Design Options

Atypical lengths

In applications where the length needs to match the space in alcoves or between pillars, all convector radiators can be ordered in lengths with 1cm increments. When determining the total length of a convector, consideration must also be given to the size of the thermostatic head, connection piping and/or access to the air vent. The units are available in lengths of up to 6 meters. Measure the unit length **L** and add length **A** for access to the air vent and length **B** for convector control as shown above.

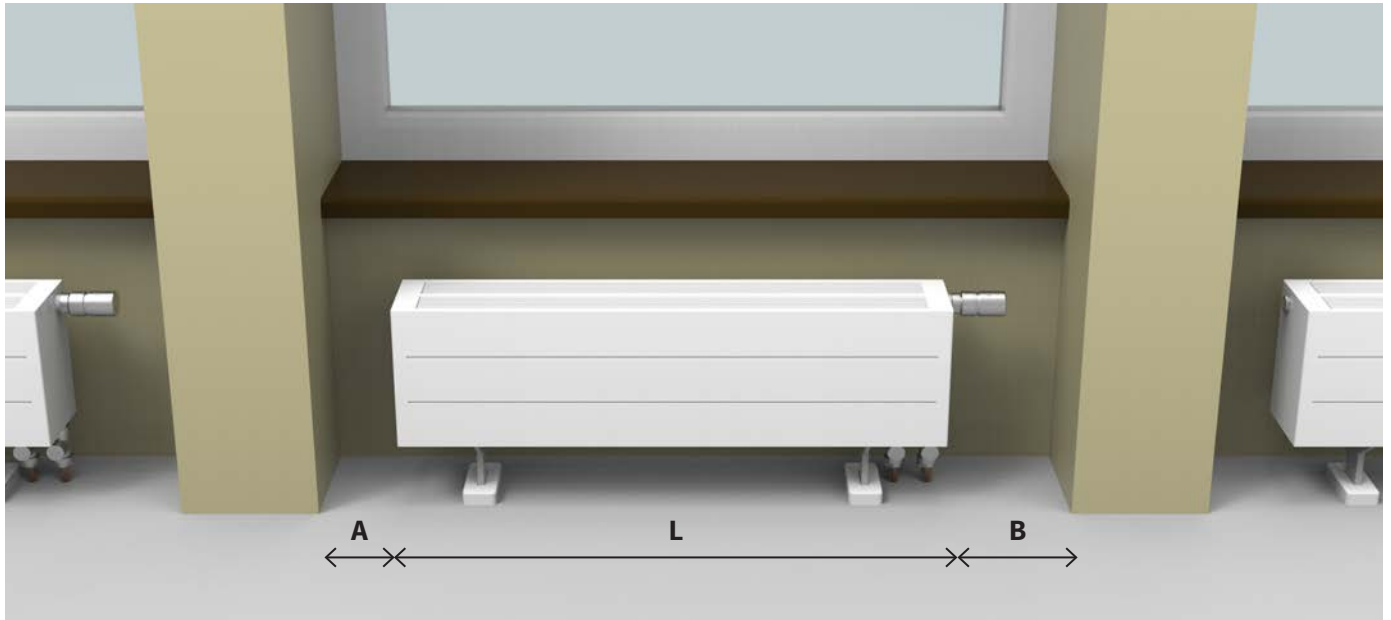

Curve

Not all interiors feature a strictly square layout. In fact, curved walls are not that uncommon when it comes to both historic and modern buildings.

The manufacturer should be consulted first about this convector option to confirm the suitability of the curved design for a particular model and the required bend radius. The curvature should match the wall whose radius rarely corresponds to design documentation. This means that an on-site measurement is a must.

The minimum inner radius of curved convectors is 2000 mm.



Suspended convectors

Church interiors, for example, are practically impossible to heat to a comfortable temperature. Convectors suspended below church pews provide effective local heating. The concealed installation offers an optimal solution for large halls where people spend time and where it is not efficient or feasible to heat the entire space. Assembly halls, waiting rooms, train stations, corridors, airports, church buildings, presbyteries, castles...

Convectors up to 6 meters in length or in-line connection options (AB - AC combination) allow for installation from one end of the pew.



One-side in-line connection of convectors hooked to a single backbone piping.

Facade radiant convector

Windows in entrance areas and lobbies can sometimes reach up to several floors high. Heating located at ground level is consequently not sufficiently effective to heat the air throughout the height of the room. This can be readily by the installation of facade convectors at each floor level.

Individual convectors can also be connected on one side from the backbone heating water line.

The method of anchoring can be modified based on specific project requirements.



Angled radiant convector

Radiant convectors can also be installed in interiors with an irregular layout, in corners and in alcoves. Corner and angled convector radiators are suitable both for modern interiors with angled glazing and for remodeled historic buildings with numerous alcoves. Given the broad variety of convector shapes and heating system connection configurations, it is important that the right sequence of steps is followed when an order is placed, starting with the basic measurements and dimensional sketching. The customer is subsequently sent a draft drawing for approval. The approved drawing becomes a binding document for the manufacture of the angled convector radiator.

The heating units are available with Block floor stands only.



RIGHT ANGLE 90° – L shape

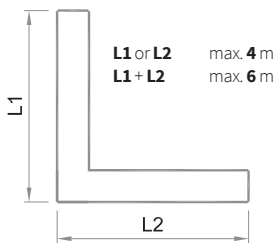

RIGHT ANGLE 90° – U shape

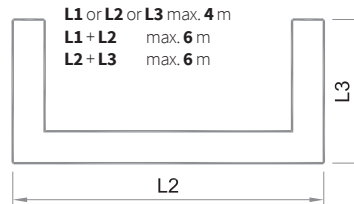

OBTUSE ANGLE – open U shape

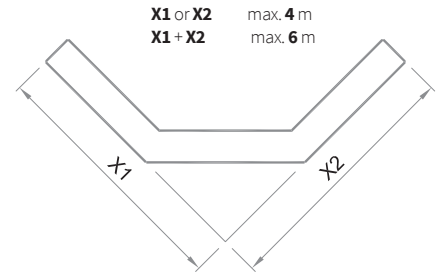

OBTUSE ANGLE – open L shape

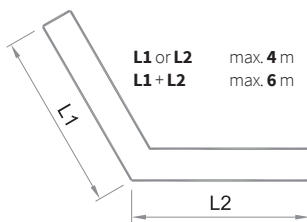

ANGLED – Z shape

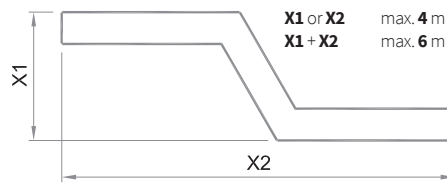

Convectors for sanitary environments

In sanitary environments, a particular emphasis is placed on the ease of cleaning the convector surfaces. This requires an open design that facilitates the removal of dust and debris from all inner and outer surfaces of the heating unit. Convectors for sanitary environments have been modified to make this possible.

The convector comes without the top grille and the inner fin surfaces.



Reference output ΔT_{50} (75/65/20 °C) [W/m]

Height / Model	K20	K30	K40	K50
H = 70 mm	208 W	285 W	354 W	415 W
H = 140 mm	308 W	433 W	546 W	649 W
H = 210 mm	408 W	581 W	738 W	882 W
H = 280 mm	508 W	728 W	930 W	1116 W

Convectors with a wooden top

A stylish wooden top turns a heating unit into a practical designer piece. It can be used as a bench, shelf or a handy countertop. Its applications include hallways, waiting rooms, auditoriums or lobbies to sit or place garments on when putting on shoes.

The wooden top is available for K32, K33W, K43, K44W, K54 and K55W models. **The convector with a wooden top cannot be fitted with an upper grille.**

Available wooden top designs

The top boards come in four versions made of solid wood. All tops are coated with a clear varnish. For other options, including the use of different wood or your own board, contact the ISAN Technical Department.

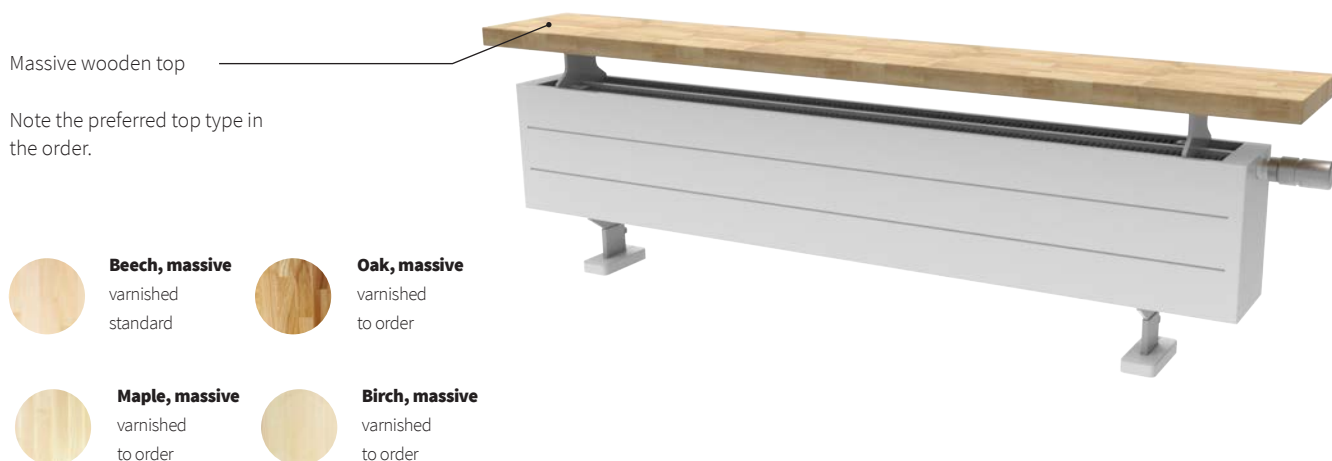

Note the preferred top type in the order.

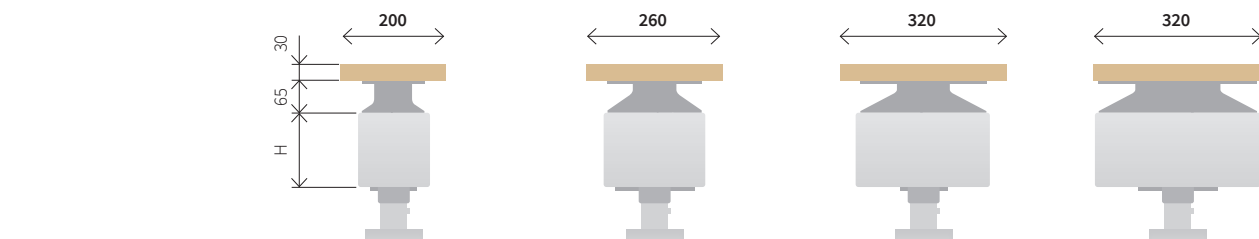

Standard connection	K22W, K32	K33W, K43	K44W, K54	K55W
----------------------------	------------------	------------------	------------------	-------------

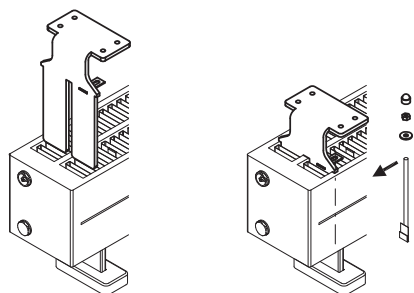
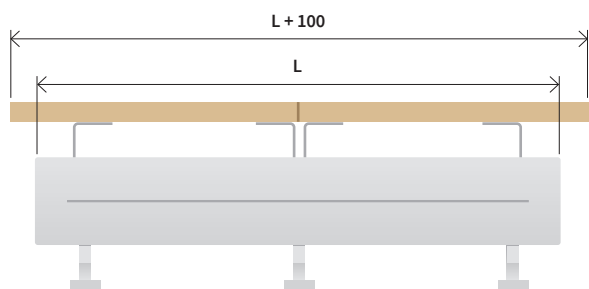

Length L [mm]	Top [pc]	Holder [pc]
400–2 000	1	2
>2 000–2 600	1	3*
>2 600–4000	2	4
>4 000–5 300	2	6
>5 300–6 000	3	6

* K54, K55W in the range >2 000-2 600 mm there are 2 wooden tops and 4 holders

Identification coding

BEECH standard	O25EBL
OAK	O25OBL
MAPLE	O25MBL
BIRCH	O25BBL
Holder	O133K

Complementary products

If you want original heating units in your home, try designing your own thick-walled steel radiators. Thanks to the manual manufacture of EXACT convectors, we are able to offer a variety of alternatives to our products. Given their increased size, these heating units are regarded as radiators.

To differentiate them from standard products, all modified models are identified with the letter F (K convectors). If you are interested in any of these products, we will be happy to provide you with more details.

Horizontal radiators with heat transfer fins

A robust designer piece that provides an alternative to commercially produced heating units.

Lamellar radiators are essentially higher convectors with modified wall mounting hardware. They are compatible with most types of connection to the heating system, just like standard convectors. The radiator height can be adjusted in 70 mm increments and their length in steps of 1 cm. The products are available in a wide range of shades as per the ISAN colour coding or the basic RAL colour chart.

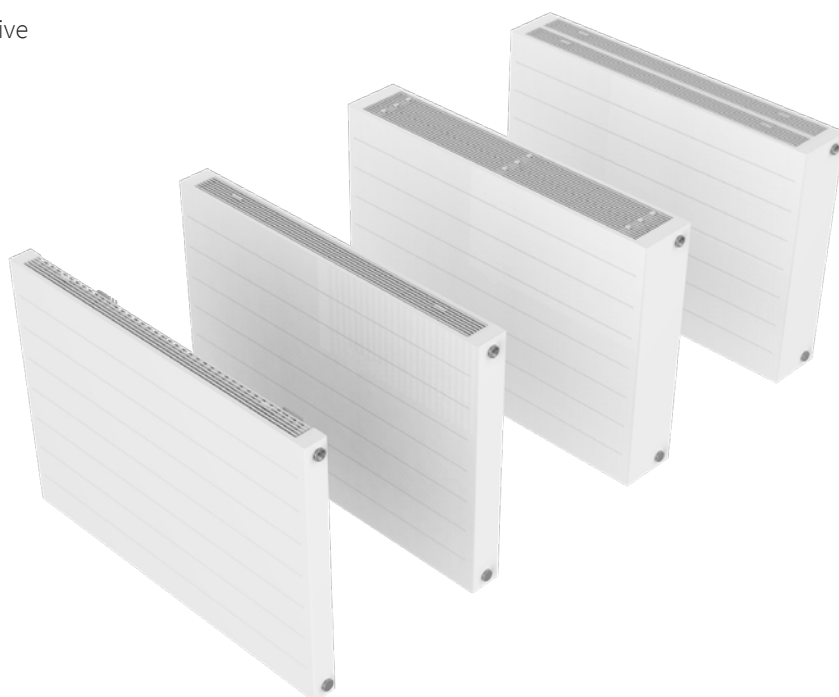

Top views

F11H



F22H

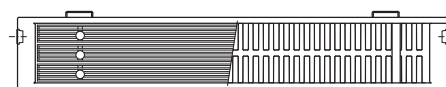

F21H



F32H

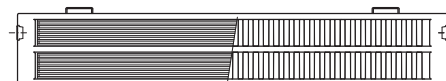

Model	Height	Width	Length	No. of radiant surfaces	No. of convection surfaces
F11H	280, 420, 560, 700 mm	50 mm*	400-3000 mm **	1	1
F21H	280, 420, 560, 700 mm	72 mm	400-3000 mm **	2	1
F22H	280, 420, 560, 700 mm	133 mm	400-3000 mm **	2	2
F32H	280, 420, 560, 700 mm	133 mm	400-3000 mm **	3	2

* VR, VL valve connection, depth 61 mm

** The maximum length is limited by the unit's weight of 150 kg

Horizontal radiators without fins

Light-weight radiant heating units

“Maximum” output is not always the most important aspect of a radiator. At a time when low-energy or passive homes are on the rise, there are tangible benefits in opting for large radiant units that look great at the same time.

The available range of sizes works well for heating both small and large rooms where the radiant component is essential to ensuring a comfortable environment inside. Larger heating units are more suitable for low thermal gradients.

Suitable for:

- family houses and apartments
- foyers and large halls
- auditoriums, lecture halls
- theatres, historic buildings

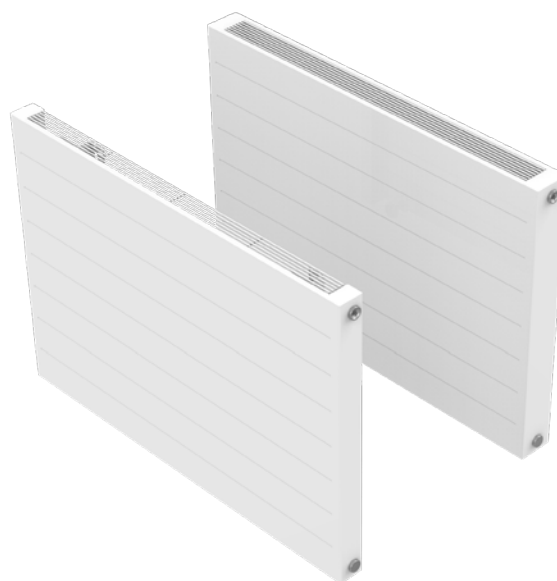

... sanitary environments

Buildings where strict hygiene requirements are a concern can be equipped with F10H and F20H units without top grilles. These units provide easy access to all inner and outer surfaces for thorough cleaning.

Suitable for:

- hospitals, hospices
- areas with stricter sanitary requirements
- schools, preschools
- auditoriums, lecture halls
- theatres, historic buildings



Model	Height	Width	Length	No. of radiant surfaces	No. of convection surfaces
F10H	280, 420, 560, 700 mm	50 mm (61 mm*)	400-3 000 mm	1	0
F20H	280, 420, 560, 700 mm	72 mm	400-3 000 mm	2	0

* depth 61 mm in models with VL, VR connection

Vertical radiators without fins

Turning standard design radiators upright gives the lamellar units an entirely new appearance.

Vertically mounted heating units will bring elegance to any interior. With the width starting at 280 mm and the height ranging up to 3000 mm, they can be customized to fit any project. The F10L model features a full size mirror with a perimeter bevel.

The F10L radiator comes with a practical hook and the mirror fixtures can also be used for hanging various items. It is a practical unit that is ideal for hallways and entrance areas.

While the F10 and F10L models have a sheet metal cover on the side, the F20V is fitted with a side grille.



Model	Height	Width	Length	No. of radiant surfaces	No. of convection surfaces
F10V	400-2000 mm	50 mm	280, 420, 560, 700 mm	1	0
F10L	1600, 1800 mm	50 mm	560, 700 mm	1	0
F20V	400-3000 mm	72 mm	280, 420, 560, 700 mm	2	0

Exact Convector Technical Drawings

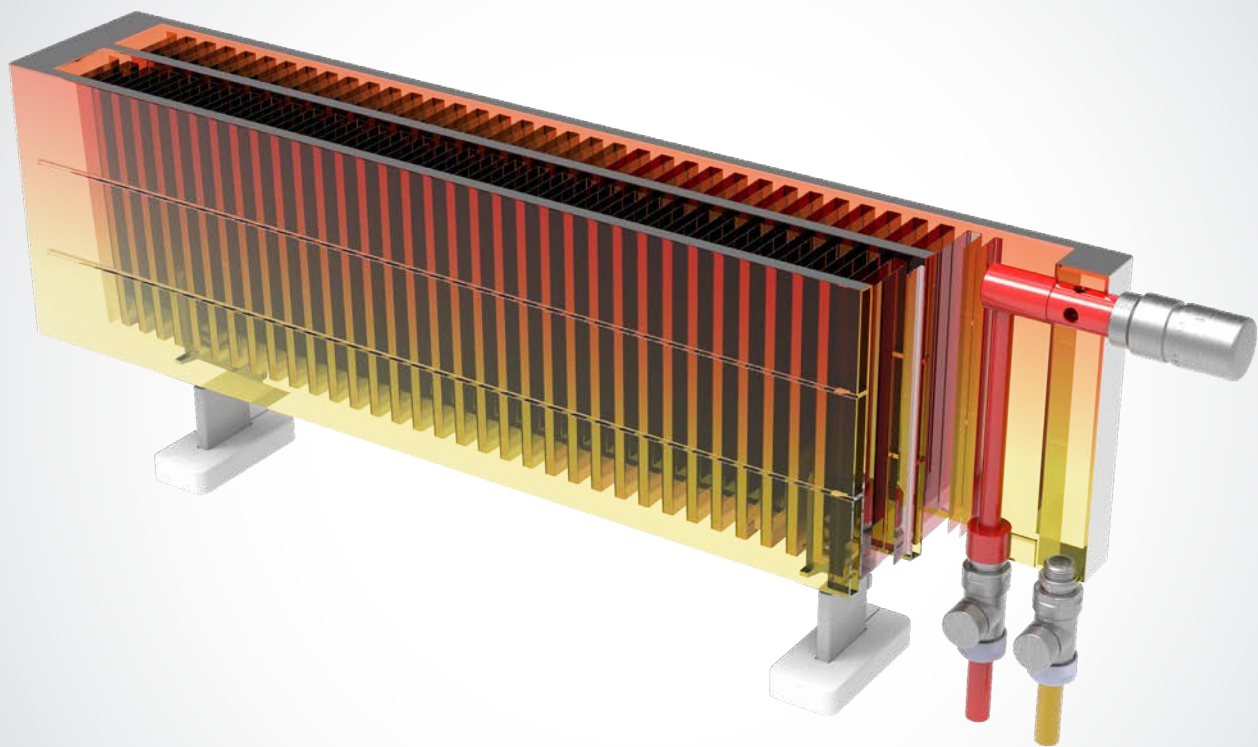

34-39

Convector drawings and connections

AB, CD, AD, CB, BD, DB, AC, CA, EF, FE CONNECTION OPTIONS	p. 34
VR, VL CONNECTION OPTIONS	p. 35
SM, MS CONNECTION OPTIONS	p. 36
SR, ML CONNECTION OPTIONS	p. 37
BLOCK FLOOR STANDS	
EE, FF CONNECTION OPTIONS	p. 38
EF, FE CONNECTION OPTIONS	p. 39

AB, CD, AD, CB, BD, DB, AC, CA, EF, FE connection options

K21, K32, K43, K54

W=72, 133, 194, 255 mm

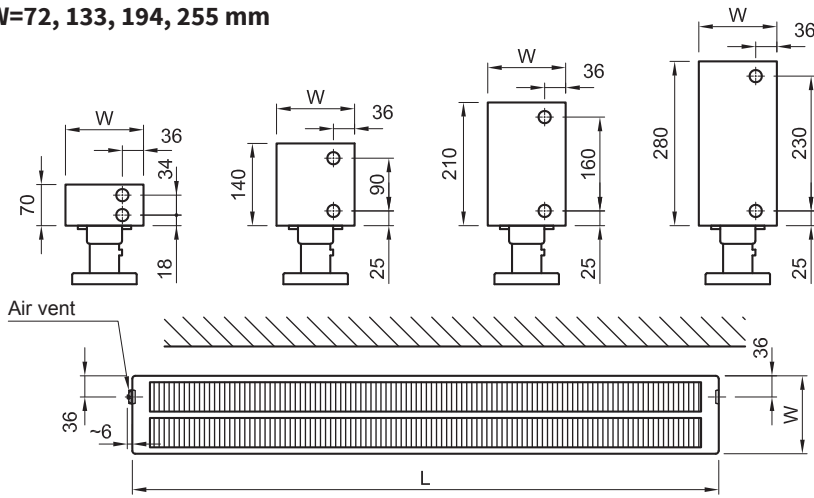

K22, K33, K44, K55

W=111, 172, 233, 294 mm

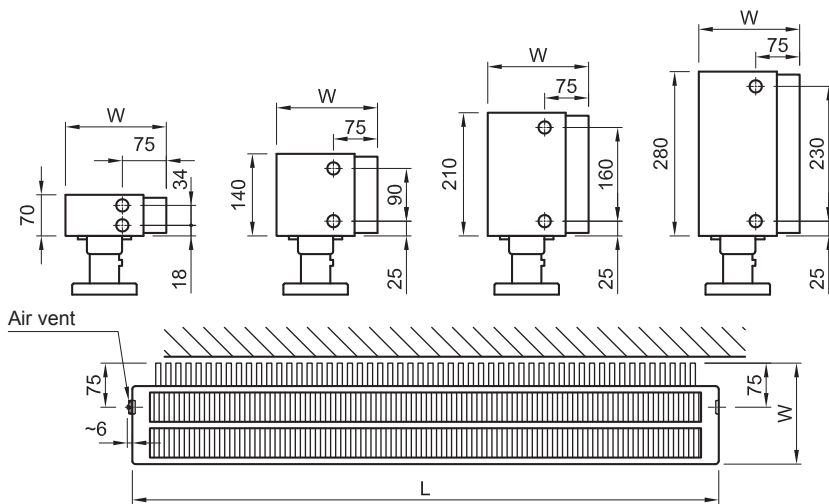

K22W, K33W, K44W, K55W

W=133, 194, 255, 316 mm

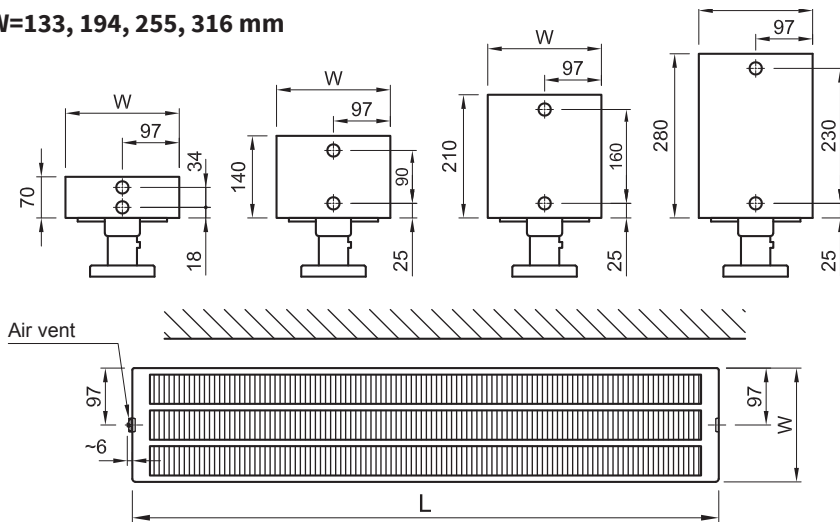

Heating system connection

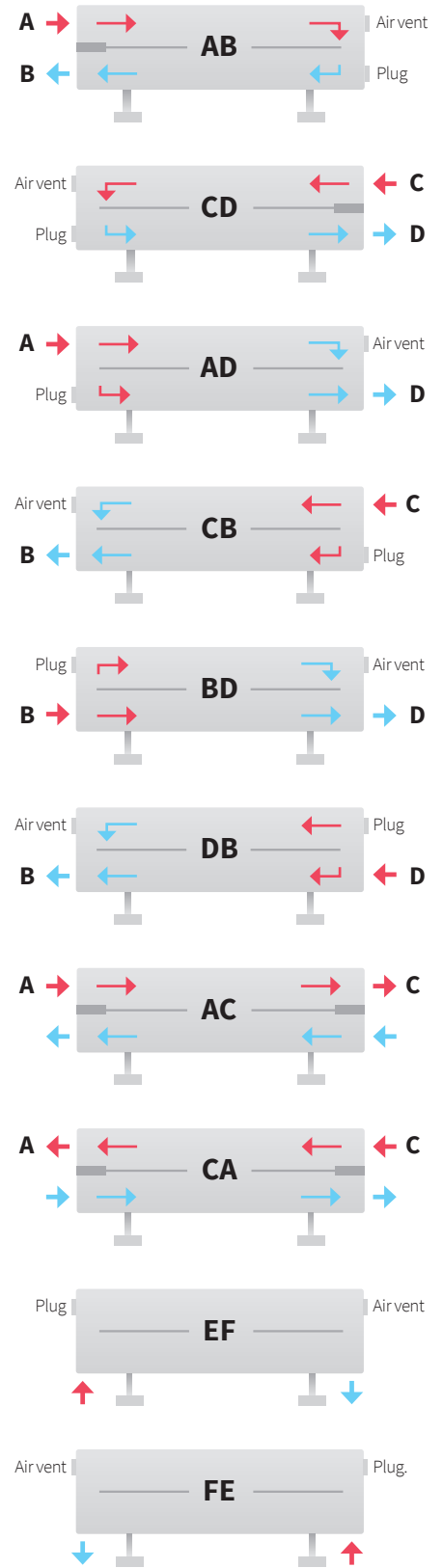

EF, FE connection – bottom view

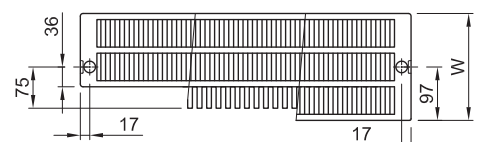

VR, VL connection options

K21, K32, K43, K54

W=72, 133, 194, 255 mm

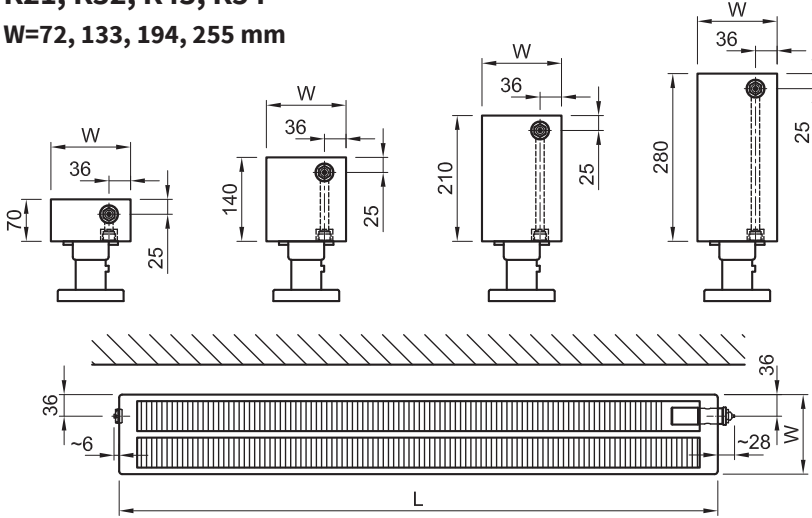

Heating system connection

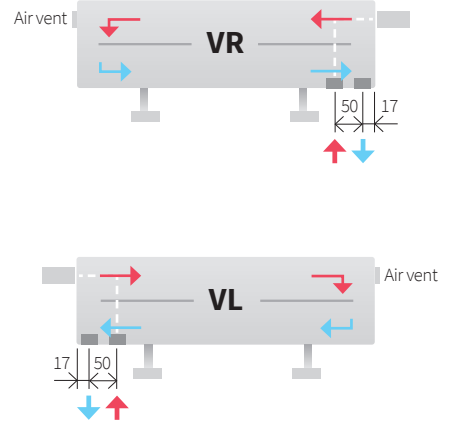

K22, K33, K44, K55

W=111, 172, 233, 294 mm

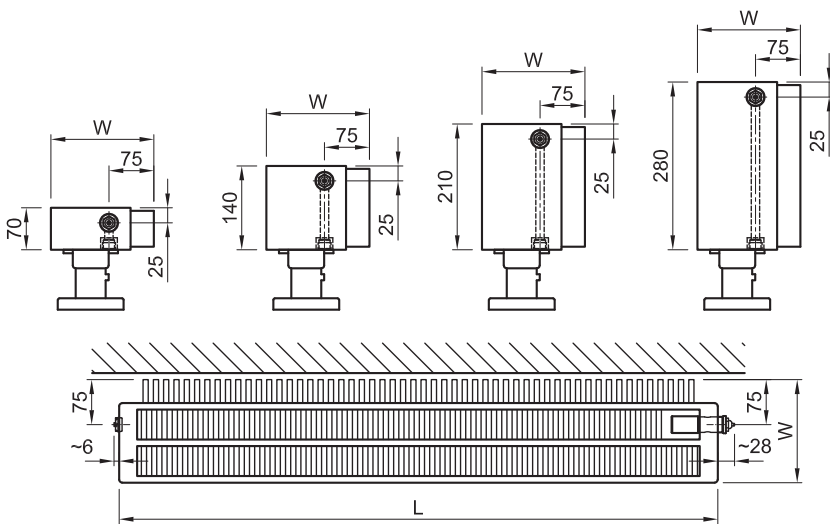

VR connection - detail

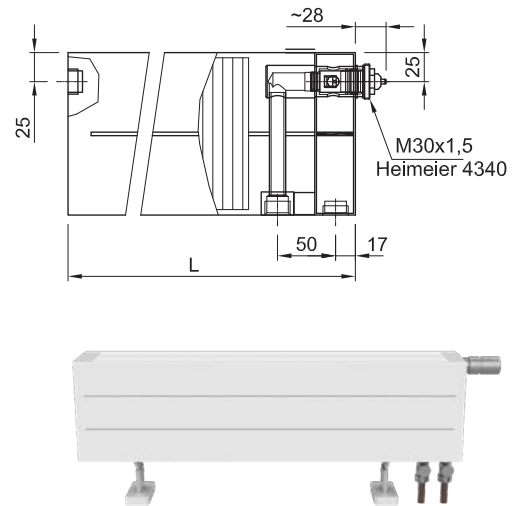

K22W, K33W, K44W, K55W

W=133, 194, 255, 316 mm

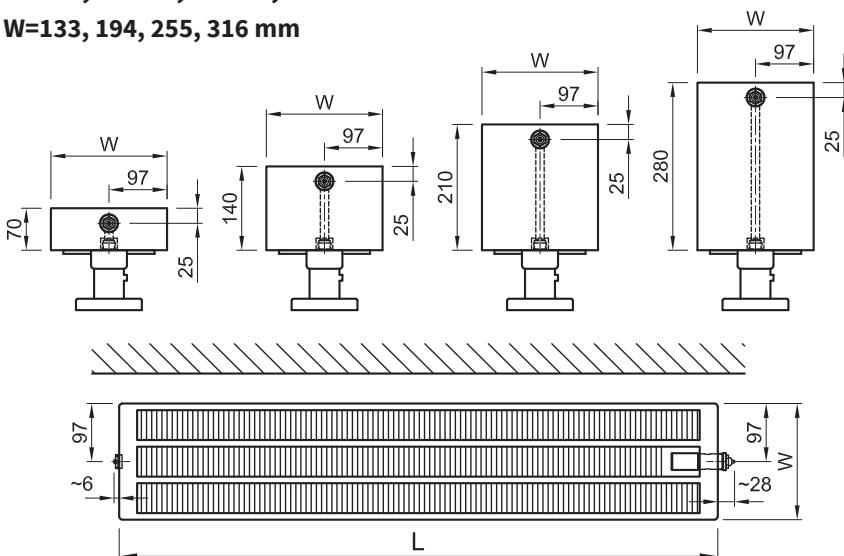

Operating principle

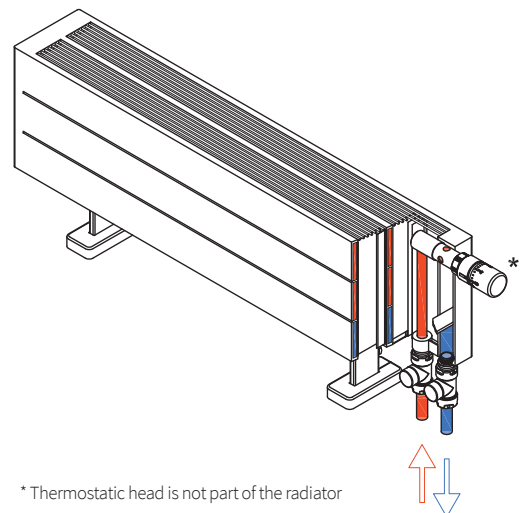

* Thermostatic head is not part of the radiator

SM, MS connection options

K21, K32, K43, K54

W=72, 133, 194, 255 mm

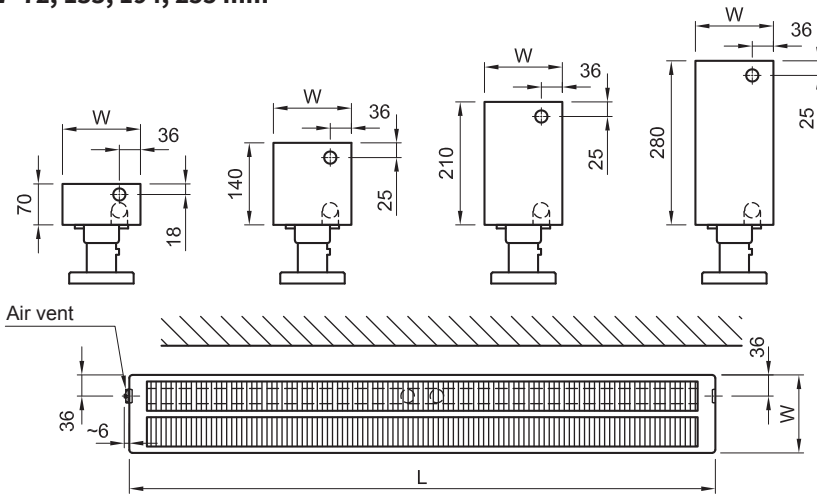

Heating system connection

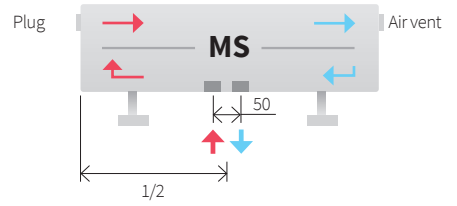
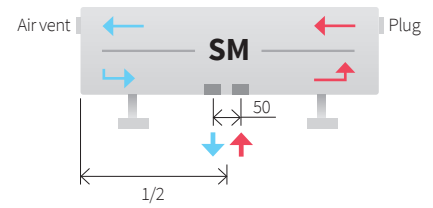

K22, K33, K44, K55

W=111, 172, 233, 294 mm

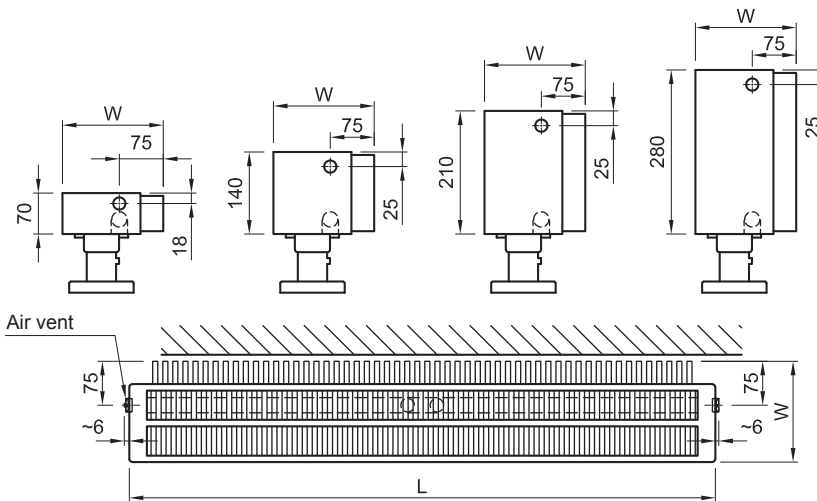

Front view of the convector



K22W, K33W, K44W, K55W

W=133, 194, 255, 316 mm

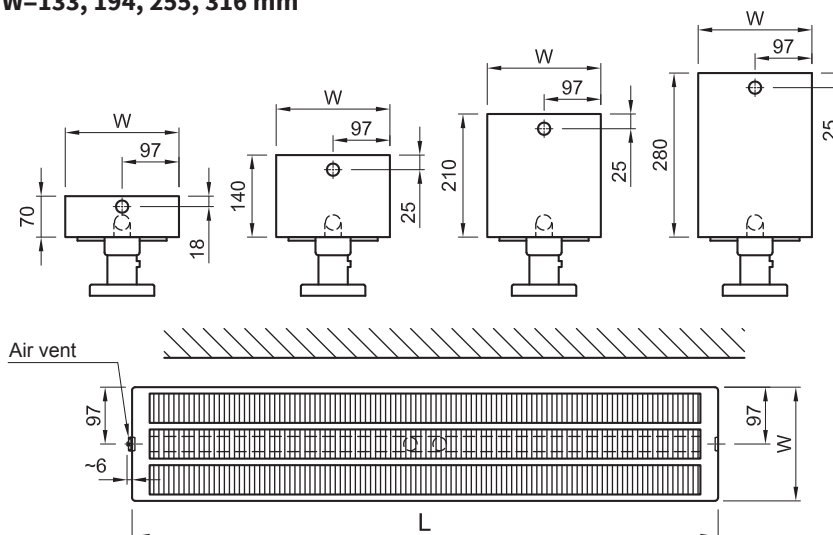

Operating principle

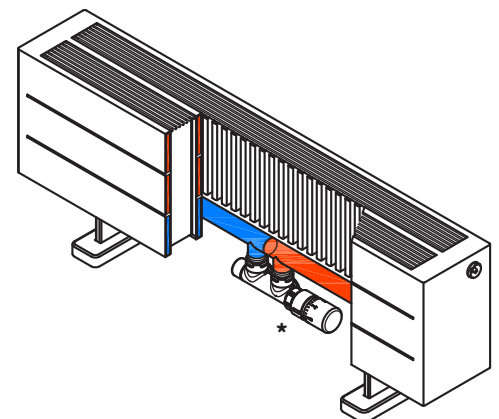

* The thermostatic head must be ordered separately

SR, ML connection options

K21, K32, K43, K54

W=72, 133, 194, 255 mm

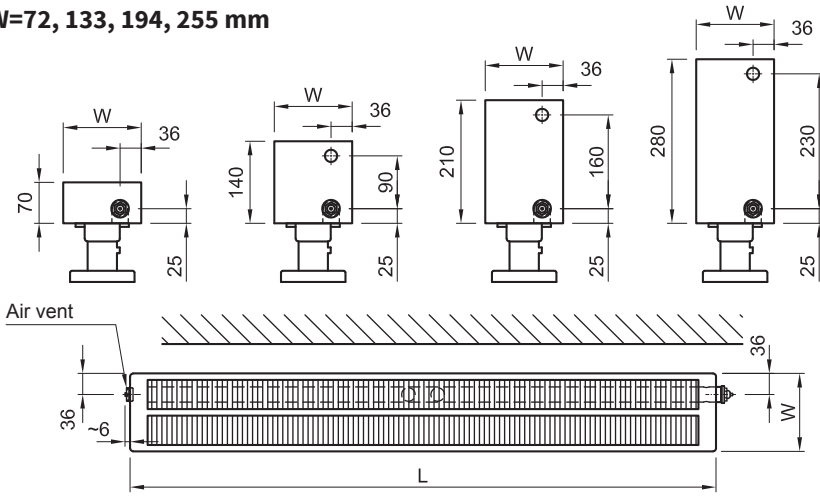

Heating system connection

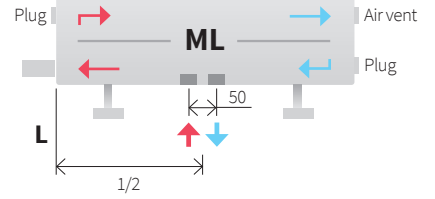
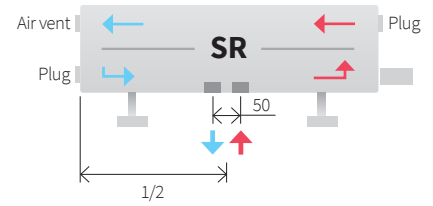

K22, K33, K44, K55

W=111, 172, 233, 294 mm

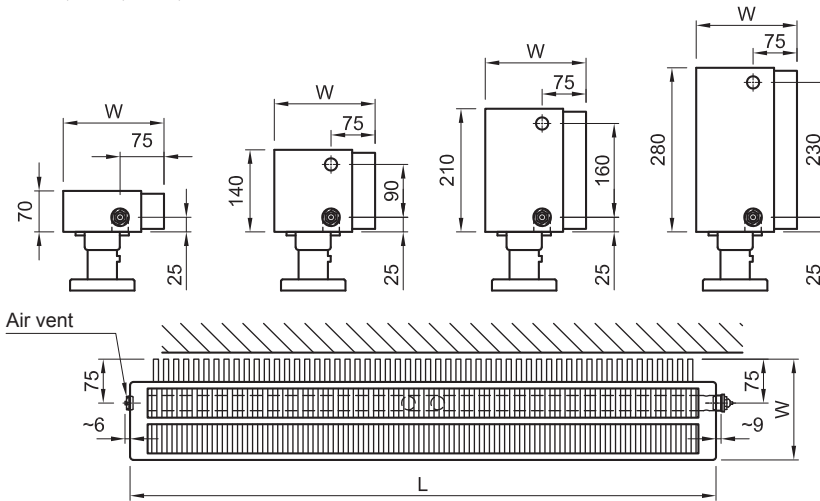

Front view of the convector



K22W, K33W, K44W, K55W

W=133, 194, 255, 316 mm

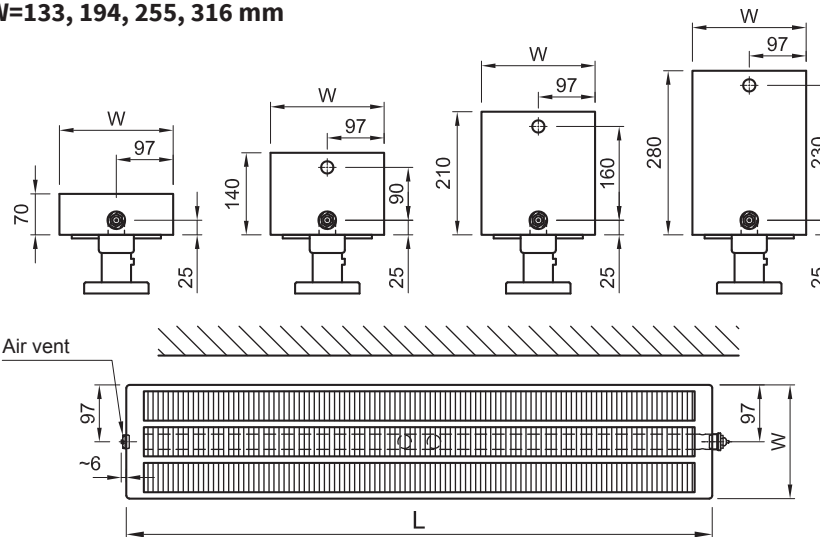

Operating principle

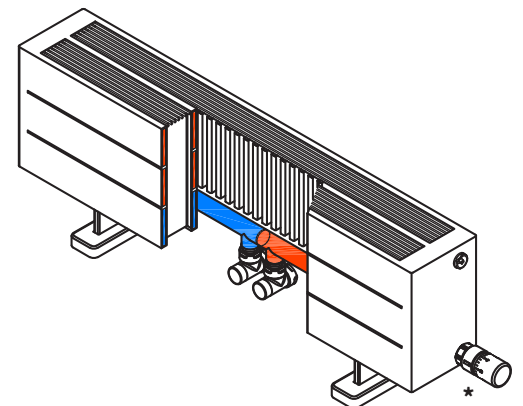

* The thermostatic head must be ordered separately

EE, FF connection options - Block floor brackets

K32, K43, K54

W= 133, 194, 255 mm

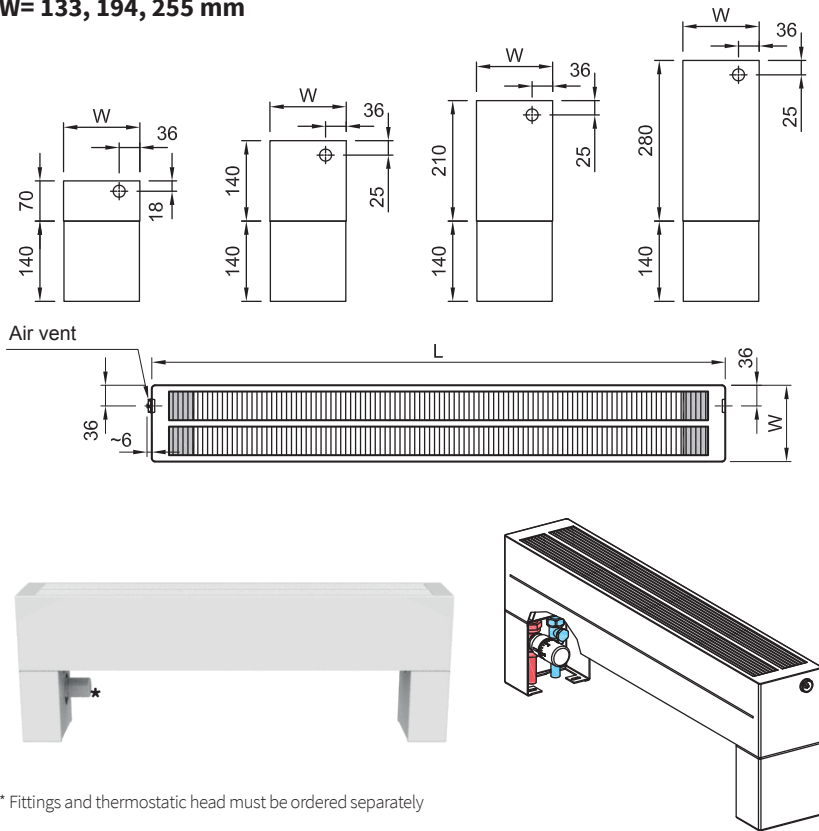

Heating system connection

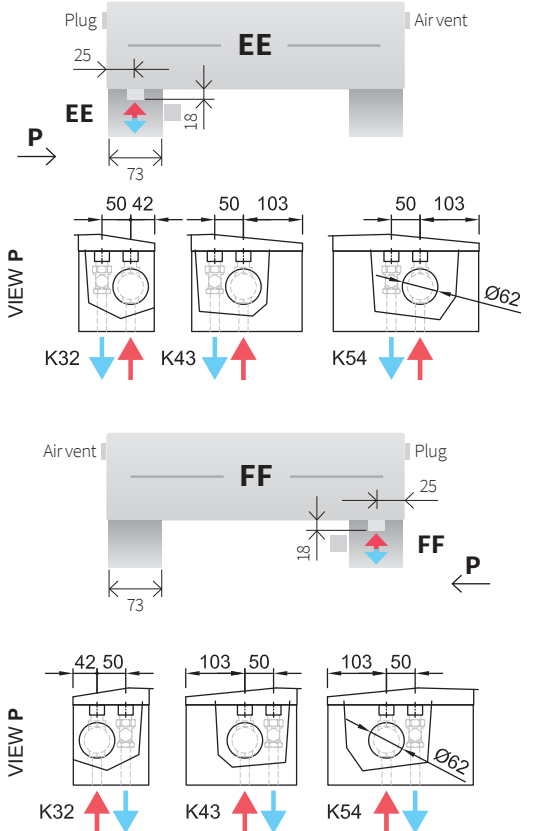

K33W, K44W, K55W

W= 194, 255, 316 mm

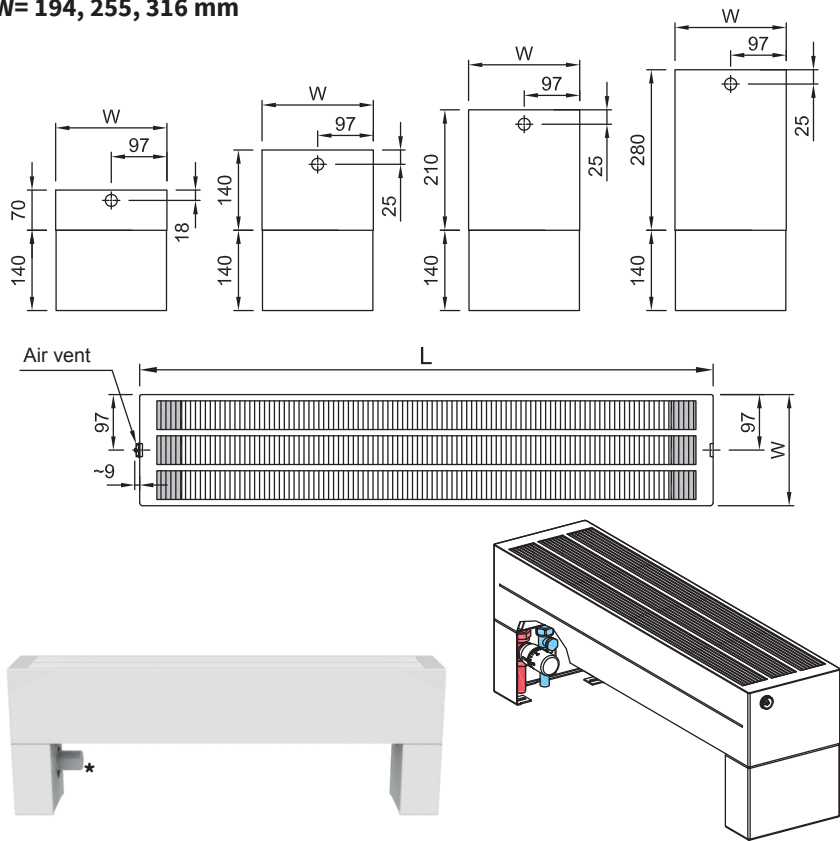

Heating system connection

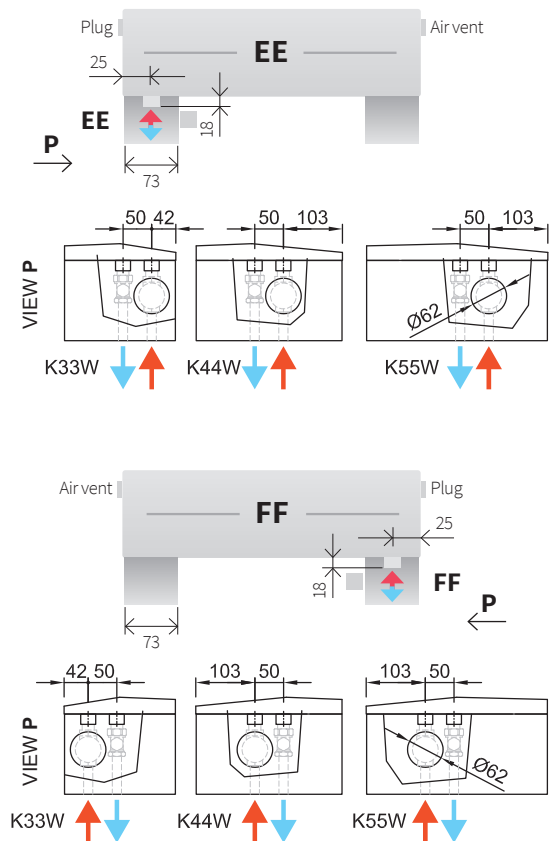

EE, FF connection options - Block floor brackets

K32, K43, K54

W= 133, 194, 255 mm

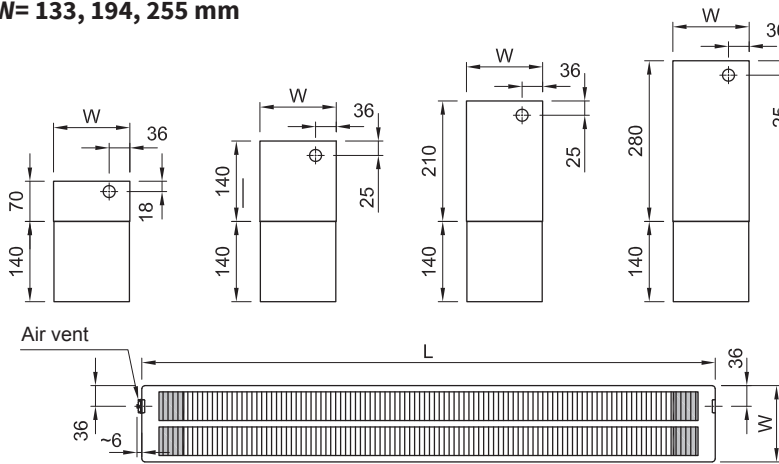

* Fittings and thermostatic head must be ordered separately

Heating system connection

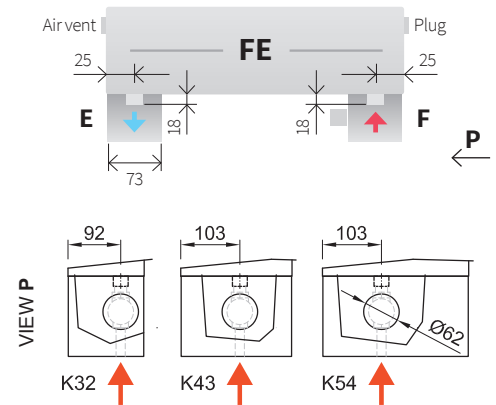
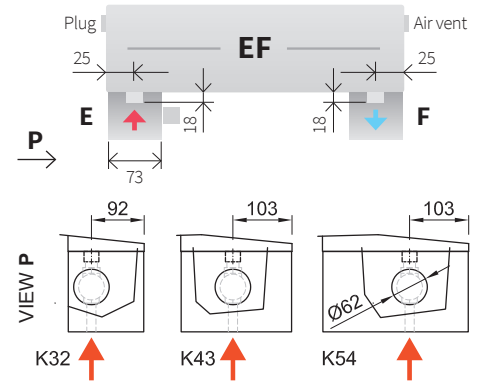

K22W, K33W, K44W, K55W

W=133, 194, 255, 316 mm

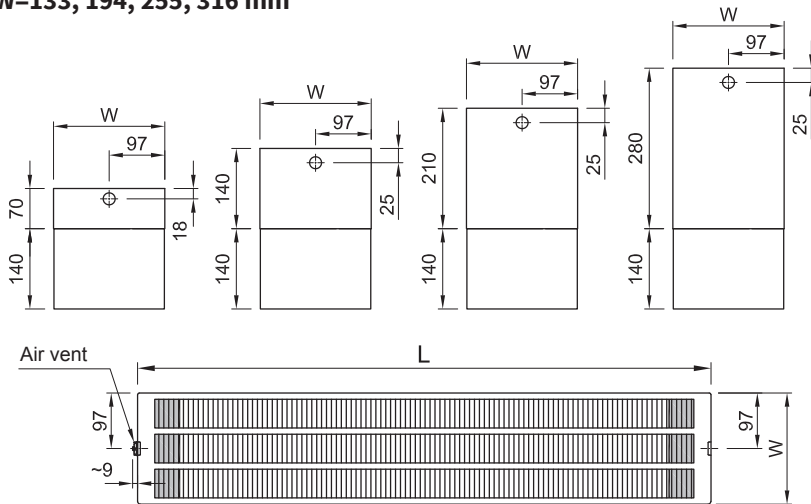

* Fittings and thermostatic head must be ordered separately

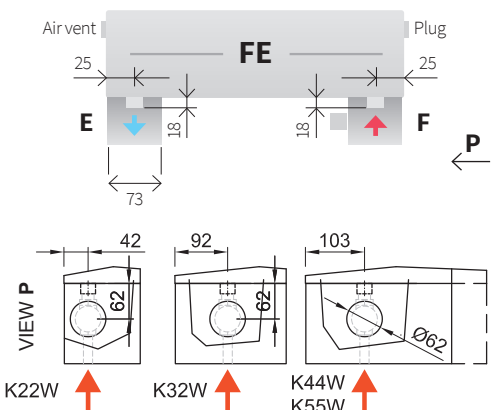
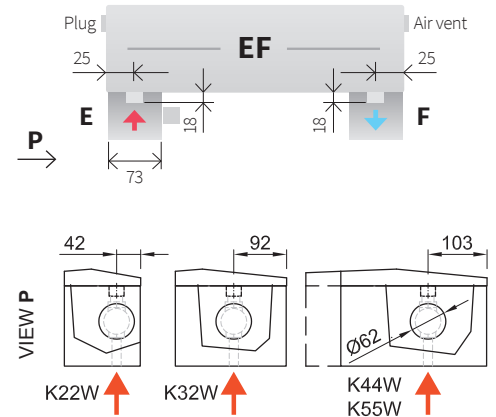

Heating system connection



Colour Reference Chart

	colour series RAL 9016 shade snow/traffic white finish gloss extra charge - code 01		colour series RAL 9016 MAT shade white matt finish matt extra charge ✓ code 05		colour series S09 shade snow-white finish texture extra charge ✓ code 68
	colour series RAL 9001 MAT shade ivory finish matt extra charge ✓ code K9		colour series RAL 1015 shade jasmine finish gloss extra charge ✓ code 12		colour series S08 shade ivory finish texture extra charge ✓ code 67
	colour series S13 shade sandstone finish texture extra charge ✓ code 72		colour series S31 shade champagne finish metallic extra charge ✓ code 25		colour series S75 shade light gold finish metallic extra charge ✓ code L1
	colour series S36 shade antique gold finish metallic extra charge ✓ code 48		colour series S19 shade brass finish metallic extra charge ✓ code 83		colour series S28 shade gold olive finish texture extra charge ✓ code 22
	colour series S03 shade copper finish metallic extra charge ✓ code 62		colour series S35 shade cinnamon finish texture extra charge ✓ code 29		colour series S59 shade dark brown finish matt extra charge ✓ code H4
	colour series S66 shade brown quartz finish texture extra charge ✓ code J9		colour series RAL 6009 shade fir green finish gloss extra charge ✓ code 43		colour series S30 shade sapphire finish texture extra charge ✓ code 24
	colour series RAL6027 MAT shade light green finish matt extra charge ✓ code K5		colour series S29 shade aquamarine finish metallic extra charge ✓ code 23		colour series RAL 7040 shade window grey finish gloss extra charge ✓ code 31
	colour series S23 shade pearl grey finish texture extra charge ✓ code 86		colour series S05 shade silver finish metallic extra charge ✓ code 64		colour series S33 shade lava ash finish texture extra charge ✓ code 27
	colour series RAL 7006 MAT shade beige grey finish matt extra charge ✓ code C7		colour series S02 shade anthracite finish metallic extra charge ✓ code 61		colour series S22 shade pearl black finish texture extra charge ✓ code 85
	colour series S40 shade black velvet finish matt extra charge ✓ code 51		colour series RAL 9005 shade black finish gloss extra charge ✓ code 19		

Special treatment

	colour series S20 shade transparent paint finish gloss extra charge ✓ code 84		colour series S41 antibacterial* shade snow white finish gloss extra charge ✓ code 88
---	--	---	--

*A silver-ion antibacterial finish provides protection against a wide range of bacteria and mildew.

The S20 "transparent paint" finish allows for visibility of the underlying surface, i.e. the steel radiator itself. All welds, processing features and the different shades of steel used (depending on the material supply) are visible. The progressive corroded appearance under the coating constitutes a natural material degradation and as such is not subject to a claim.

Coding

1-4				5-8				9-12				13-14		15-16		17	18-19		20	
K	2	2	W	0	2	1	0	1	6	5	0	A	B	F	2	D	0	1	T	
PRODUCT				HEIGHT				LENGTH				CONNECTION		SUPPORT		GRILLE		COLOUR		ATYPICAL/ STANDARD

The K22W radiant convector, with two radiant and two convection heat-transfer surfaces and a window shield to prevent heat escaping through the window, convector height 210 mm, atypical length 1,650 mm, one-sided AB connection on the unit's left side, stands Subtle, grille with rectangular holes, snow white RAL9016, atypical design for operating overpressure of 10 bar (1.0 MPa).

1-4 PRODUCT	K21-	convector depth 72 mm, 2× radiant surface, 1× finned heat-transfer surface
	K32-	convector depth 133 mm, 3× radiant surface, 2× finned heat-transfer surface
	K43-	convector depth 194 mm, 4× radiant surface, 3× finned heat-transfer surface
	K54-	convector depth 255 mm, 5× radiant surface, 4× finned heat-transfer surface
	K22-	convector depth 111 mm, 2× radiant surface, 2× finned heat-transfer surface
	K33-	convector depth 172 mm, 3× radiant surface, 3× finned heat-transfer surface
	K44-	convector depth 233 mm, 4× radiant surface, 4× finned heat-transfer surface
	K55-	convector depth 294 mm, 5× radiant surface, 5× finned heat-transfer surface
	K22W	convector depth 133 mm, 2× radiant surface, 2× finned heat-transfer surface, window shield
	K33W	convector depth 194 mm, 3× radiant surface, 3× finned heat-transfer surface, window shield
	K44W	convector depth 255 mm, 4× radiant surface, 4× finned heat-transfer surface, window shield
	K55W	convector depth 316 mm, 5× radiant surface, 5× finned heat-transfer surface, window shield
5-8 HEIGHT [mm]	70	0070
	140	0140
	210	0210
	280	0280
9-12 LENGTH [mm]	400 - 2000 in step 100 mm	0400, 0500, 0600, 0700, 0800, 0900, 1000, 1100,2000
	2200 - 6000 in step 200 mm	2200, 2400, 2600, 2800, 3000, 3200, 3300,, 6000
13-14 CONNECTION	AB	one-sided (left)
	CD	one-sided (right)
	AD	diagonal (inlet on the left)
	CB	diagonal (inlet on the right)
	BD	bottom continuous (inlet on the left)
	DB	bottom continuous (inlet on the right)
	AC	continuous (inlet on the left)
	CA	continuous (inlet on the right)
	EF	bottom (inlet on the left)
	FE	bottom (inlet on the right)
	MS	middle (inlet on the left)
	SM	middle (inlet on the right)
	VL	with the thermostatic valve on the left
	VR	with the thermostatic valve on the right
	ML	middle with the thermostatic valve on the left
	SR	middle with the thermostatic valve on the right
	EE	bottom one-sided in-line, left (the Block floor stands version only)
	FF	bottom one-sided in-line, right (the Block floor stands version only)
15-16 SUPPORT	F2	flat floor stands – Subtle
	P1	floor stands made of steel strip
	F6	double flooring floor stands Tall
	W2	wall brackets – Subtle
	S1	floor stands – Block
	R1	fixed low stand Rigid R1, the stands meet the criteria of the VDI 6036 Class 3
	R2	adjustable stand Rigid R2, the stands meet the criteria of the VDI 6036 Class 3
R3	high double flooring stand Rigid R3, the stands meet the criteria of the VDI 6036 Class 3	

17 GRILLE	-	no grille (standard)
	L	linear grille
	D	grille with rectangular holes
	V	grille with round holes
18-19 COLOUR	01	standard Snow White RAL 9016 (see the ISAN chart on p. 40)
	99	colour different than the ISAN chart
	structured colours	
	metallic colours	
	colours as per RAL colour chart	
20 ATYP	-	standard design without modifications
	N	atypical design, to be specified in the note after the product code (e.g. length 1265 mm)
	X	design 1.0 MPa (10 bar)
	T	design 1.0 MPa (10 bar) + atypical convector design
	C	corner version of the convector, 6 bar only
	R	radius version of the convector, 6 bar only



isan.cz/en/



ISAN Radiátory s.r.o

Poříčí 26
678 01 Blansko
Česká republika

CZ

obchod@isan.cz

SK

obchod@isan.sk

Export

sales@isan.cz