

HRA-1

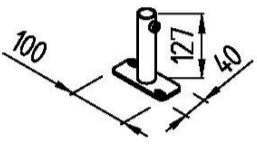

Ø32



Ø57, Ø76

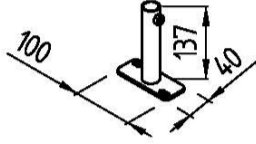

Ø89, Ø108

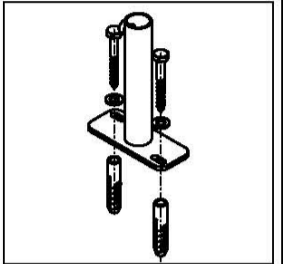
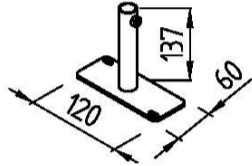

Ø32

4x Ø10 (L=500-2900)
6x Ø10 (L=2901-4500)
8x Ø10 (L=4501-6000)

Ø57, Ø76, Ø89, Ø108
4x Ø10 (L=500-3000)
6x Ø10 (L=3001-4500)
8x Ø10 (L=4501-6000)

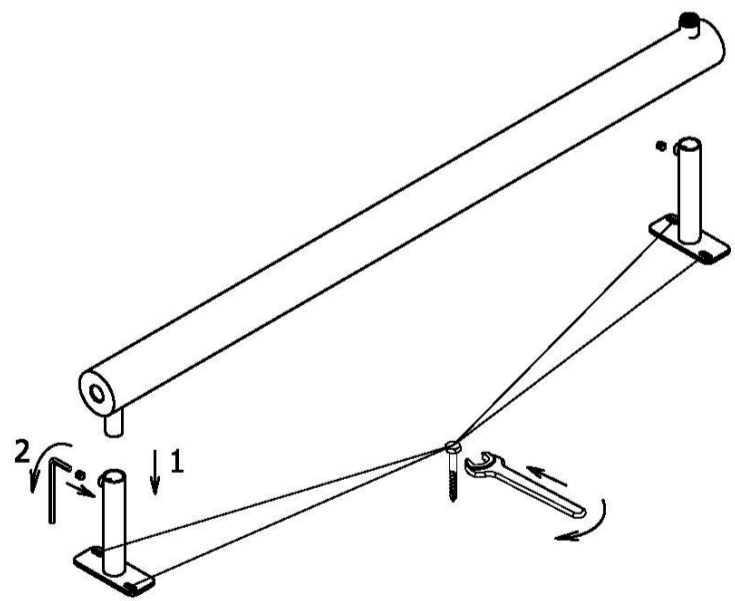
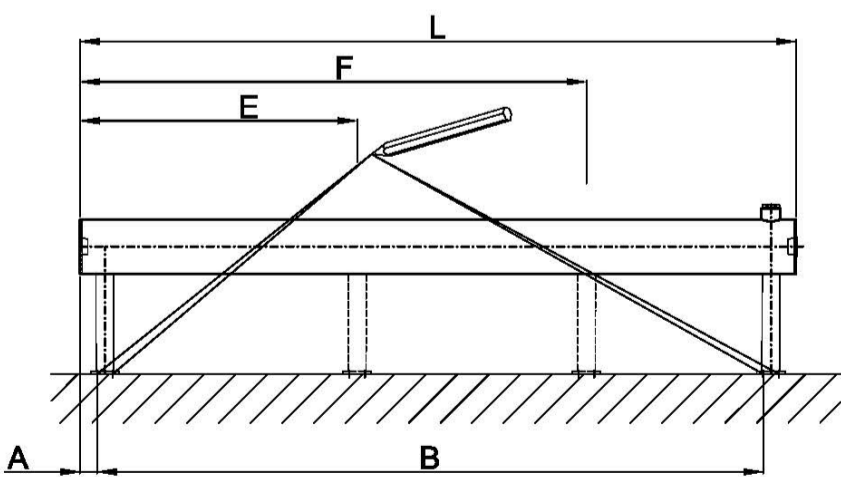
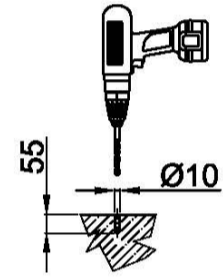
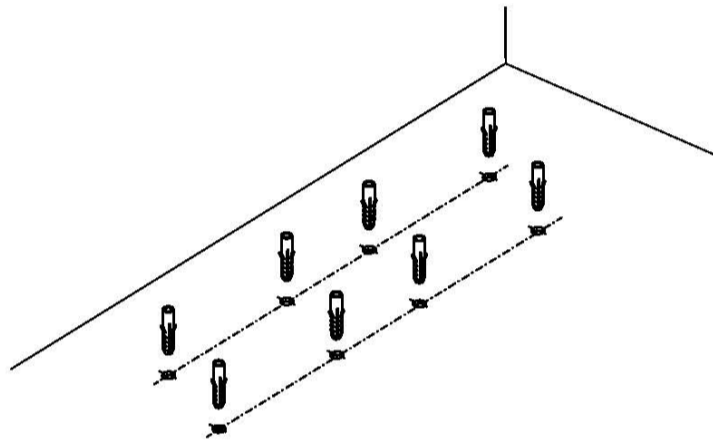

| Model | A | B | E=0, F=0 | E= \sim L/2, F=0 | E= \sim 1/3L, F= \sim 2/3L |
|-----------|----|------|----------|--------------------|--------------------------------|
| Ø32xØ92 | 14 | L-50 | L<2900 | L=2901-4500 | L>4501 |
| Ø57xØ137 | 23 | L-70 | L<3000 | L=3001-4500 | L>4501 |
| Ø76xØ156 | 23 | L-70 | | | |
| Ø89xØ169 | 14 | L-70 | | | |
| Ø108xØ188 | 14 | L-70 | | | |

HRA-1



4x Ø10 (L=500-2900)
 6x Ø10 (L=2901-4500)
 8x Ø10 (L=4501-6000)

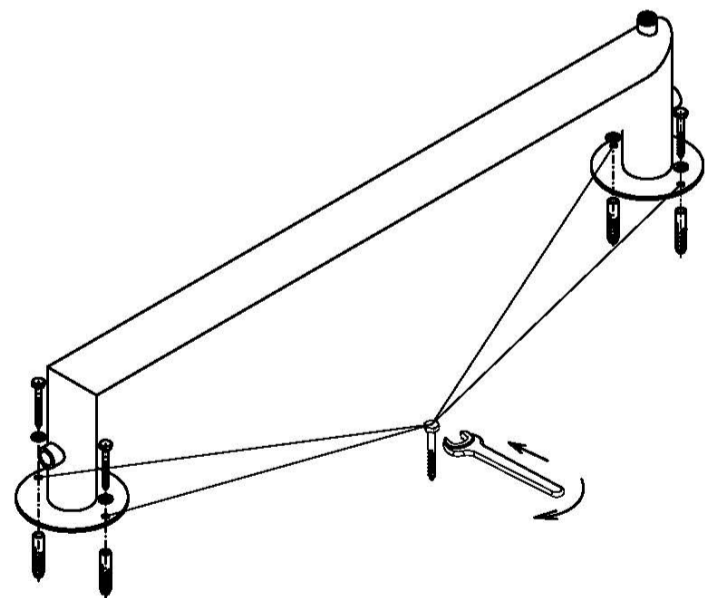
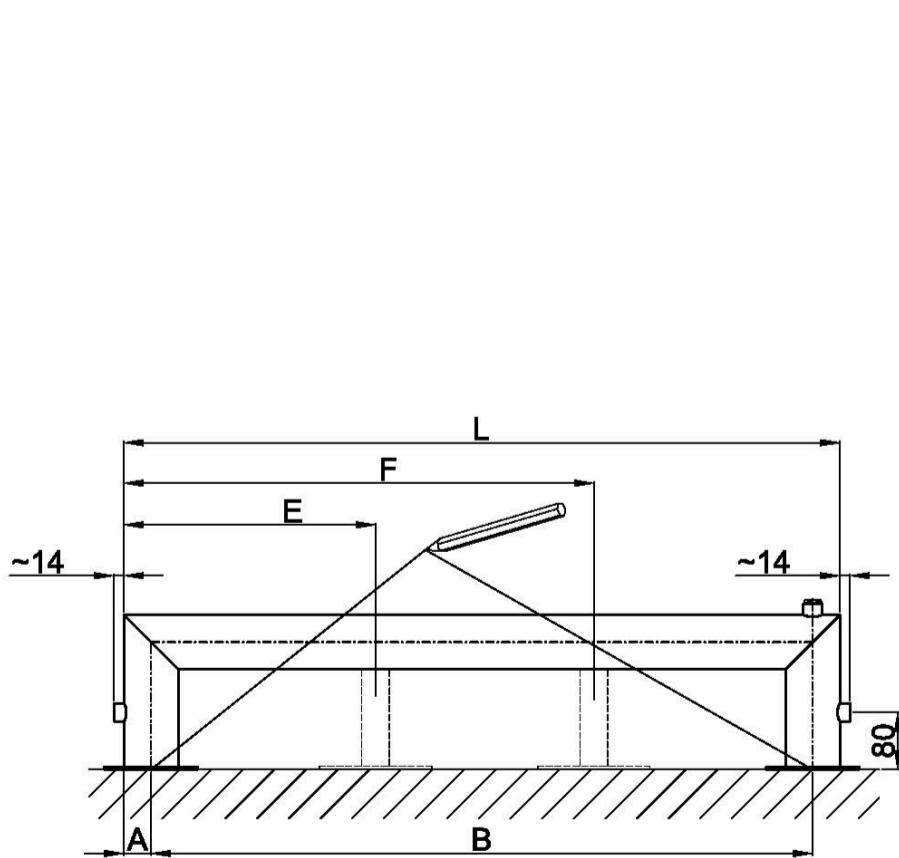
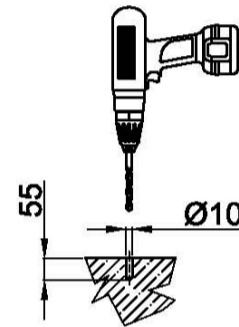
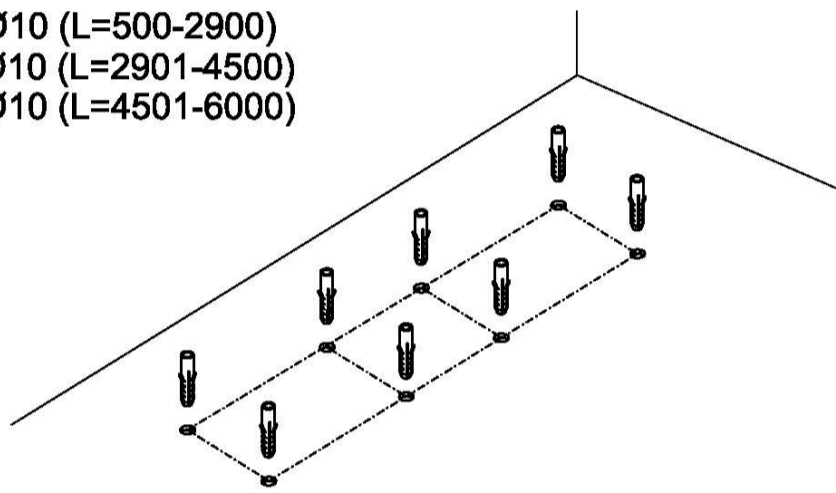

| Model | A | B | E=0, F=0 | E= \sim L/2, F=0 | E= \sim 1/3L, F= \sim 2/3L |
|-----------|----|-------|----------|--------------------|--------------------------------|
| Ø32xØ92 | 16 | L-32 | L<2900 | L=2901-4500 | L>4501 |
| Ø57xØ137 | 29 | L-57 | L<3000 | L=3001-4500 | L>4501 |
| Ø76xØ156 | 38 | L-76 | | | |
| Ø89xØ169 | 45 | L-89 | | | |
| Ø108xØ188 | 54 | L-108 | | | |

HRA-1

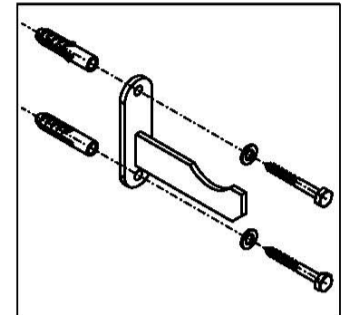
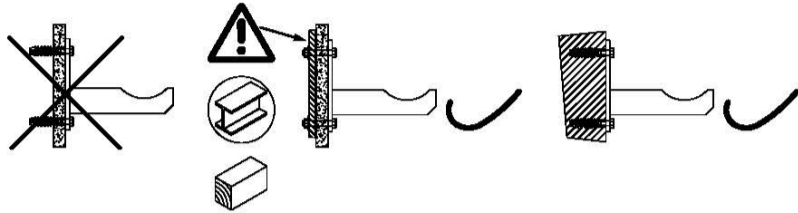

Ø32

- 2x Ø10 (L=500-2900)
- 3x Ø10 (L=2901-4500)
- 4x Ø10 (L=4501-6000)

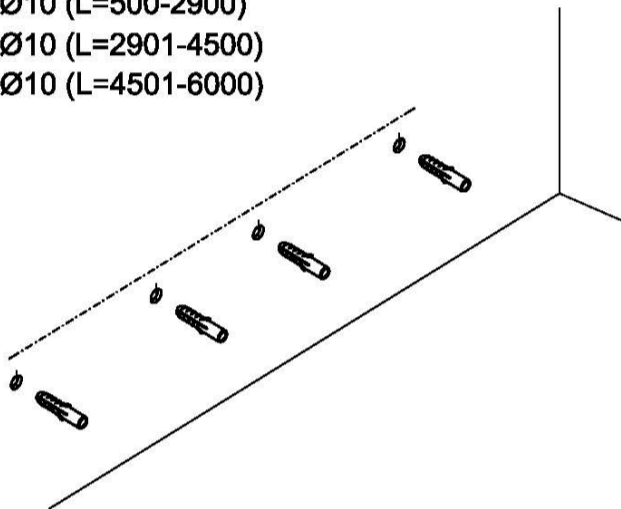

Ø57, Ø76, Ø89, Ø108

- 4x Ø10 (L=500-3000)
- 6x Ø10 (L=3001-4500)
- 8x Ø10 (L=4501-6000)

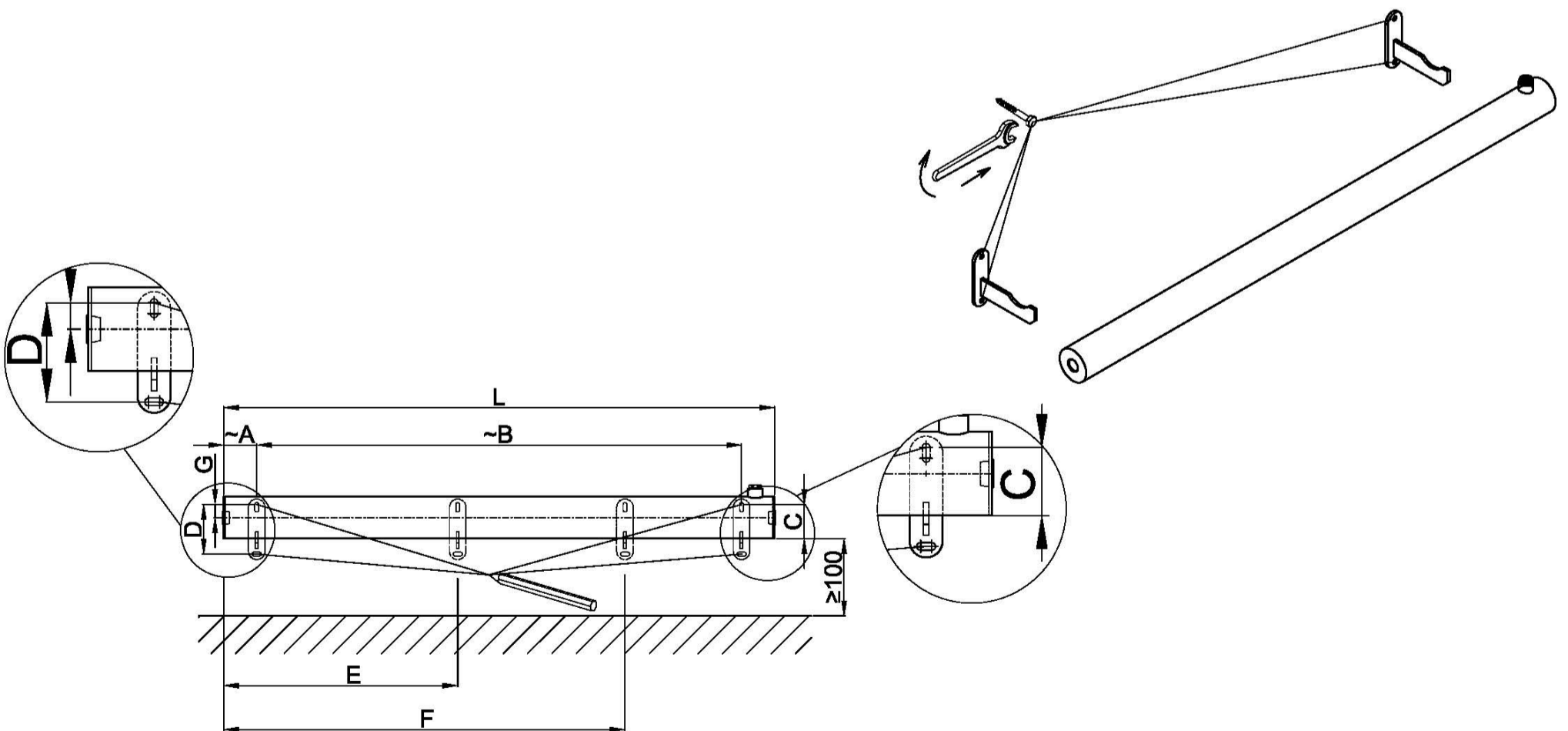
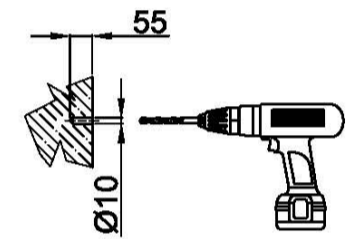
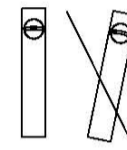
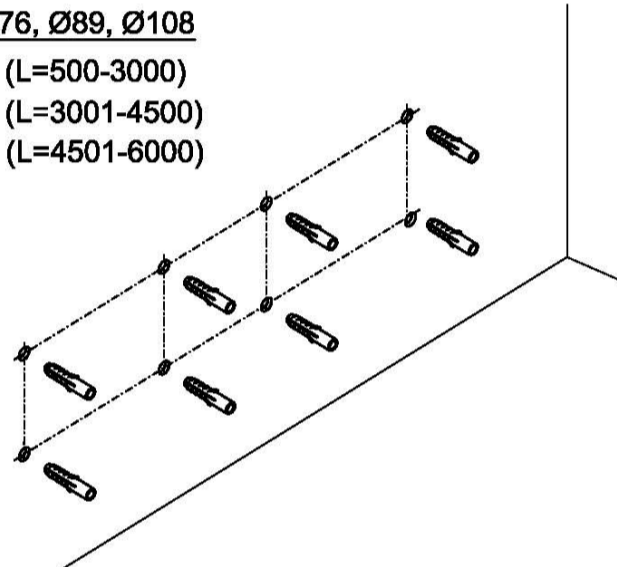

| Model | A | B | C | D | G | E=0, F=0 | E~L/2, F=0 | E~1/3L, F~2/3L |
|-----------|----|-------|----|-----|----|----------|-------------|----------------|
| Ø32xØ92 | 40 | L-80 | 55 | - | 39 | L<2900 | L=2901-4500 | L>4501 |
| Ø57xØ137 | 60 | L-120 | 50 | 80 | 22 | L<3000 | L=3001-4500 | L>4501 |
| Ø76xØ156 | 60 | L-120 | 62 | 90 | 24 | | | |
| Ø89xØ169 | 60 | L-120 | 75 | 95 | 18 | | | |
| Ø108xØ188 | 60 | L-120 | 75 | 105 | 16 | | | |

HRA-1

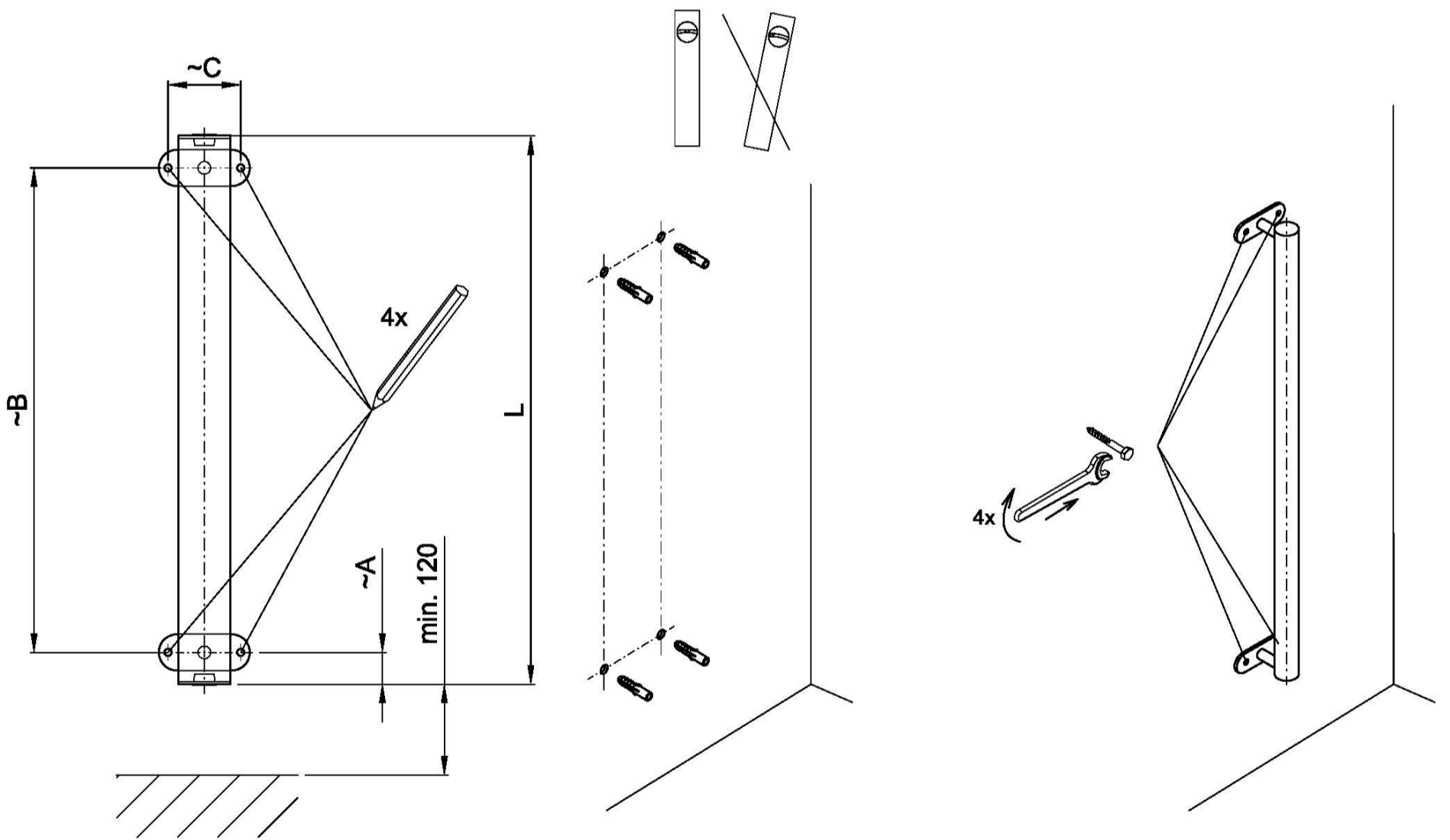
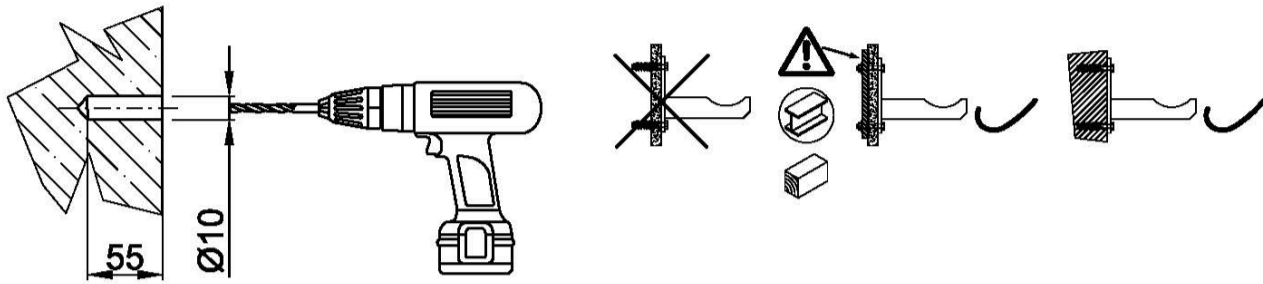

| typ | A | B | C |
|-------------------|----|------|-----|
| $\varnothing 32$ | 25 | L-50 | 80 |
| $\varnothing 57$ | 35 | L-70 | 80 |
| $\varnothing 76$ | 35 | L-70 | 80 |
| $\varnothing 89$ | 35 | L-70 | 110 |
| $\varnothing 108$ | 35 | L-70 | 110 |